

AB-1 Edit Suite User Guide

Contents

Controls and Back Panel

Chapter 1 • Introduction

- Overview of Edit Suite
- A Few Words About Time Code
- The Edit Decision List

Chapter 2 • Overview of the Keyboard

Chapter 3 • Getting Started

Chapter 4 • Making a Production

- Assemble Editing
- Auto-Assemble Editing

Chapter 5 • The NEW Menu and Edit Suite Events

- New Menu
- Scene (A/B/C/D) Events
- Source (SRC) Events
- MX1 Events
- Mixer Events
- GPI Events
- Insert (INS) Events
- Split Insert (SPLT) Events
- Stop Events

Chapter 6 • Managing The Edit Decision List

Chapter 7 • Fine Tuning

Chapter 8 • Importing and Exporting

- Export
- Import
- CMX

Chapter 9 • Setup and Configuration Menus

Chapter 10 • Error Messages and Troubleshooting

Appendix A • VCR Tables

- PANA (Panasonic Control-M) Protocol
- LANC (Control-L) Protocol
- RS-422 Protocol
- RS-232 Protocol
- VCR Infrared Code List

Appendix B • Cables and Cable Pinouts

Appendix C • Equipment Hookup

Appendix D • Edit Control Chart

Appendix E • Key Reference

Appendix F • Off-Line Logsheet

Index

2.01 Addendum

CONTROLS

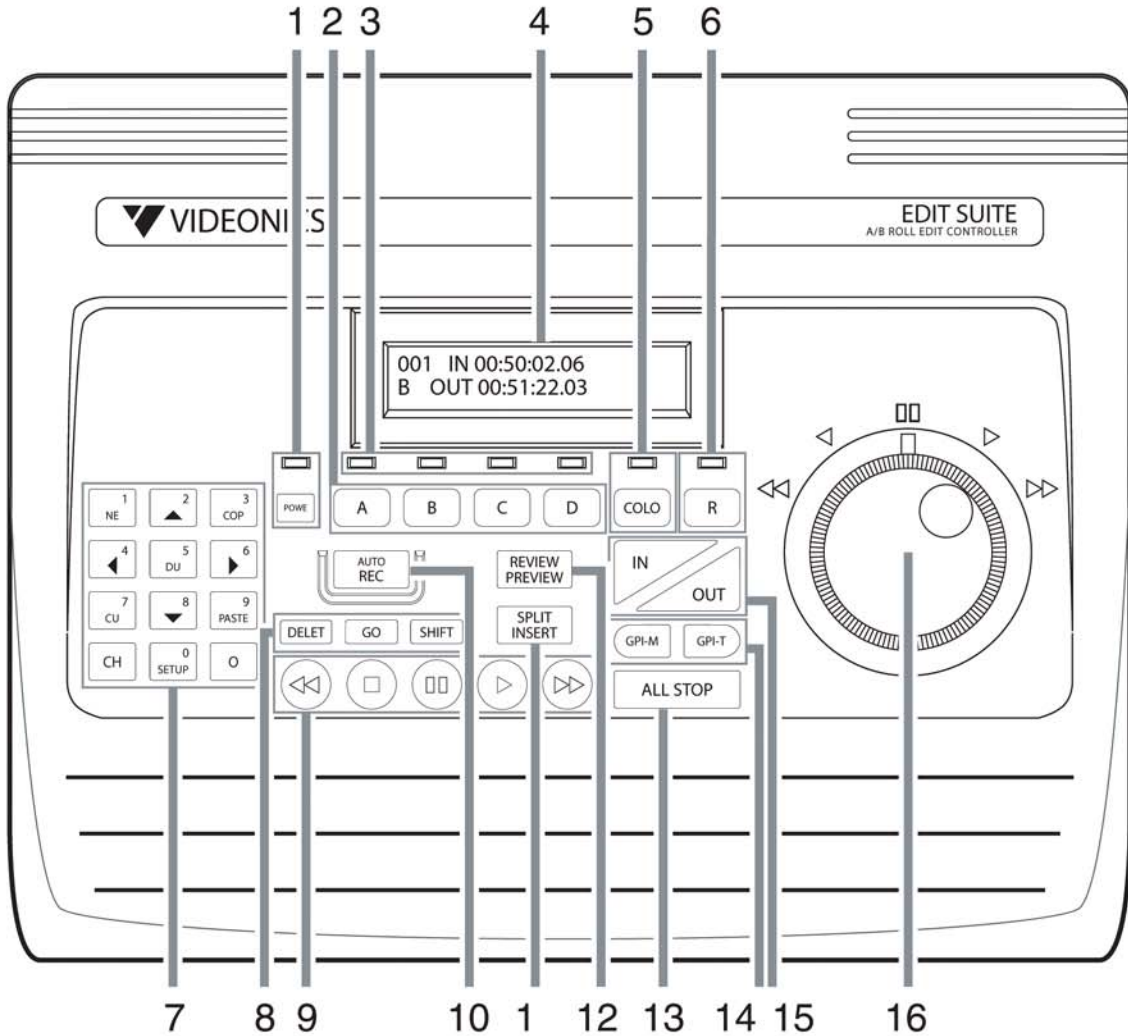

- | | |
|---|---|
| <ol style="list-style-type: none"> 1. POWER KEY AND INDICATOR 2. VCR / SOURCE SELECTOR KEYS 3. VCR / SOURCE INDICATORS 4. 40 CHARACTER BACKLIT LCD 5. COLOR SOURCE SELECTOR KEY 6. RECORDER SELECTOR KEY 7. FUNCTION / NUMERIC KEYPAD 8. MODIFIER KEYS 9. VCR TRANSPORT KEYS | <ol style="list-style-type: none"> 10. AUTO RECORD KEY (MANUAL OR AUTOMATIC ASSEMBLY) 11. INSERT / SPLIT KEY 12. PREVIEW / REVIEW KEY 13. ALL STOP KEY (HALTS ANY ACTION IN PROGRESS) 14. GPI-M / GPI-T KEYS (FOR MARKING TRIGGER EVENTS) 15. IN / OUT KEYS (FOR MARKING TAPE LOCATIONS) 16. JOG/SHUTTLE WHEEL |
|---|---|

REAR PANEL

JACKS ARE LABELED UPSIDE DOWN AT TOP OF PANEL TO FACILITATE CONNECTIONS WITHOUT TURNING UNIT AROUND.

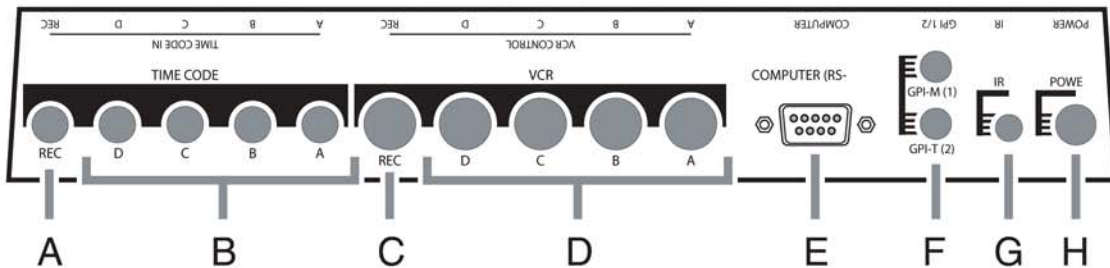

- | | |
|--|--|
| <ol style="list-style-type: none"> A. RECORD VCR TIME CODE INPUT B. PLAY VCR TIME CODE INPUTS C. RECORD VCR CONTROL PORT D. PLAY VCR CONTROL PORTS | <ol style="list-style-type: none"> E. COMPUTER INTERFACE (RS-232C) F. GPI-M (1) AND GPI-T (2) PORTS G. INFRARED WAND (RECORD VCR ONLY) H. POWER CONNECTION |
|--|--|

Chapter 1 • Introduction

Edit Suite is a full-featured video editor that can simultaneously control up to four play VCRs/camcorders, a record VCR, a mixer and a titler.

Edit Suite supports all of the primary editing control protocols—Sony Control-L (LANC), Panasonic 5-pin (Control M), RS-232 and RS-422—so you can work with a wide variety of VCRs and camcorders from a consumer level up to the professional level simultaneously. Edit Suite even supports record VCRs with Infrared control!

Edit Suite reads all of the major time codes—LTC, VITC and RCTC—so you can get time-code accuracy with all of your productions. If your VCRs do not support time code, Edit Suite will use the Real Time Counter as its source for timing information.

Whether you have one play VCR and one recorder or a full complement of VCRs, camcorders, mixers and titlers, Edit Suite will adapt to meet your needs.

How to Proceed

The remaining pages in this chapter provide a brief overview of Edit Suite, starting with how Edit Suite fits in with the rest of your equipment, and ending with an introduction to the Edit Decision List.

Chapter 2 introduces the Edit Suite keyboard. Skim through Chapter 2, spending just enough time to recall the primary functions and locations of the keys.

Next, proceed with Chapter 3, *Getting Started*. In Chapter 3 you will configure Edit Suite for use with your equipment, hook up and test your connections, then create, preview and record an A/A Roll. If you have a mixer and two play sources, Chapter 3 will also walk you through an A/B Roll.

Chapter 4 introduces assemble and auto-assemble editing, Chapter 5 provides detailed information about each type of event you can create with Edit Suite, and Chapter 6 shows you how to manage the Edit Decision List.

Fine Tuning is covered in Chapter 7. Use the fine-tuning procedures to adjust the timing Edit Suite uses during an auto-record. Chapter 8 describes Edit Suite's import and export capabilities. Chapter 9 describes the Setup and Configuration Menus, and Chapter 10 describes the error messages you may encounter. It also provides troubleshooting procedures for typical problems.

For More Information...

...send in your registration card so we can keep you informed of new developments and send you our newsletter. Note that Videonics does not sell its mailing list. Your name and address will remain confidential.

An Overview of Edit Suite

Edit Suite is compatible with a wide range of VCRs, camcorders and editing equipment, such as video mixers and switchers, title generators, video processors and audio mixers.

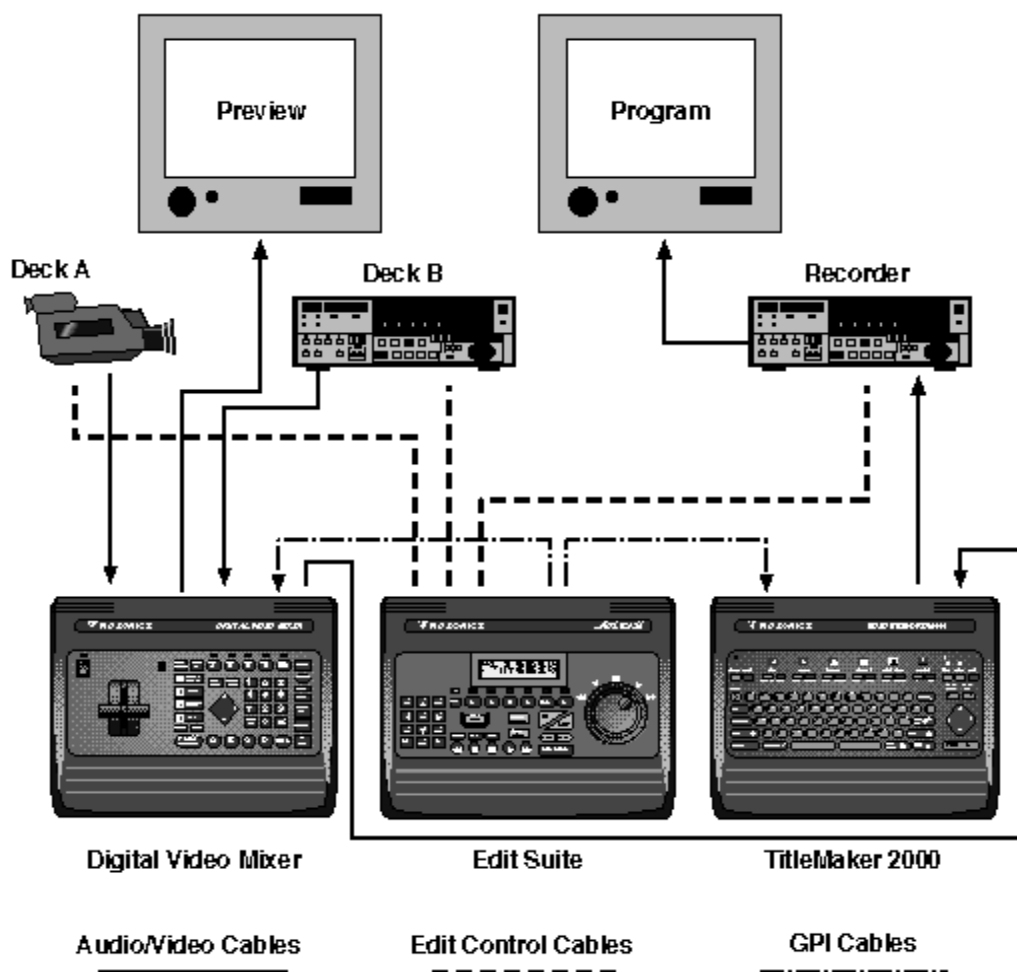

This figure shows a fairly typical configuration for Edit Suite. It includes two play sources (Deck A and Deck B), a recorder, a Videonics MX-1 Mixer (left), a Videonics TitleMaker 2000 (right), and Edit Suite in the middle to control the show. Up to two more play VCRs can be added to Edit Suite and the MX-1, or you can even add noncontrollable sources like live cameraa or pattern generators to the MX-1 and then just tell Edit Suite when you want to record video from those sources.

The Audio/Video Cables: No Video Passes Through Edit Suite

Follow the path of the Audio/Video Cables. Audio and video signals are sent directly from each play VCR/camcorder to the MX-1, from the MX-1 to the TitleMaker, and from the TitleMaker to the Recorder. No video or audio passes through Edit Suite.

Edit Suite does not need to "see" the video—it just needs to know where the video is located. You provide part of this information by locating and viewing the scenes you want to include in your production. Your VCRs and camcorders provide the rest of the information by telling Edit Suite where on that videotape the scenes start and stop. The start and stop locations are usually sent over the Edit Control Cables.

The Edit Control Cables

Trace the path of the Edit Control Cables. Each cable goes directly between Edit Suite and a VCR or camcorder. The Edit Control cables are used by Edit Suite to send commands to the VCRs and camcorders. The VCRs respond by changing operating modes, telling Edit Suite their current time code or Real Time Counter position, and by telling Edit Suite what mode they are in (Stop, Play, Fast Forward, etc.).

The GPI Cables

Trace the path of the GPI (general purpose interface) cables. One cable goes from Edit Suite to the MX-1. A second goes from Edit Suite to the TitleMaker. For most devices except the MX-1, Edit Suite sends a GPI *trigger* down the cable which causes a titler to play a screen of titles or a mixer/switcher to cut or transition from one VCR to another.

With a Videonics MX-1, in addition to triggering the transitions, Edit Suite also sends all the setup information the MX-1 needs to run the transition. It selects the MX-1's *Current* and *Next* sources automatically, it tells the MX-1 which transition to use and at what speed and direction that transition should be played, and it sets the color choices for the background and border.

A Few Words About Time Code

Time code is a digital code that is recorded on and identifies each frame of a video. When displayed, time code is in an hours:minutes:seconds.frames format (hh:mm:ss.ff). Because the time code is a part of the videotape, Edit Suite can search for a specific time-code value, and the video associated with that value will be the same every time.

Without time code, Edit Suite must rely on the Real Time Counter in your VCR or camcorder to locate your scenes. Because there is not a fixed relationship between the counter and the tape position, the video that displays at a specific counter position may be slightly different each time you search to that position. With proper care and setup, you can still create accurate productions, but they will not be quite as accurate as when time code is used. Appendix D has a more detailed discussion of time code and edit

accuracy.

A Few More Words About Time Code

Some VCRs and camcorders provide the ability to both read and write time code, and many of these can send the time code over the Edit Control Cable. For example, RCTC (rewriteable consumer time code), or a variant of RCTC, is available on many LANC and RS-232 VCRs. RCTC is always sent over the Edit Control Cable.

LTC (Longitudinal Time Code) is written in an audio track on the videotape. With most RS-422 and RS-232 VCRs that support LTC, the time code is sent through the Edit Control Cable. If you play the tape in a VCR that uses LANC or PANA protocol, the LTC will not be sent through the Edit Cable. Instead, it must be sent from the VCR/camcorder through an audio cable that you connect to the Time Code IN port on Edit Suite.

The third major time code—VITC (vertical interval time code)—is written in the video signal a little bit above the video that normally displays on your monitor. As with LTC, if VITC is played on a VCR that uses LANC or PANA protocol, it must be sent over a cable attached to Edit Suite's Time Code IN ports. Since VITC is recorded in the video portion of the tape, you must attach a cable from your VCR's video OUT port.

The Edit Decision List

When you play your videotapes and see the video you want to record, you create a Scene Event to tell Edit Suite which VCR contains the footage you are viewing, where that scene starts, and where that scene ends. You just push a few buttons—Edit Suite fills in the information for you. (Or you can type in the time codes manually.)

Each time you locate a scene you want in your production, you create a new Scene Event. Edit Suite stores the events in a list called the Edit Decision List, or EDL. You can store up to 250 events in the EDL at one time.

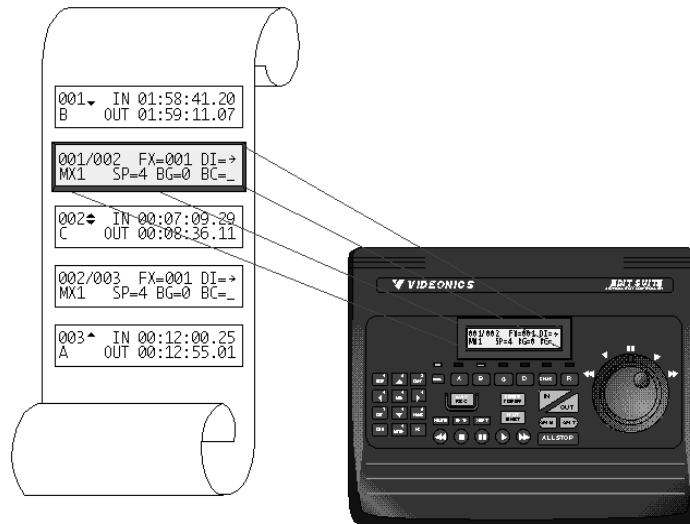

After you have created a few Scene Events, you can tell Edit Suite to preview or record the events. It will march down the Edit Decision List finding each of your scenes, controlling your recorder and play VCRs, and creating your production.

Now leaf through Chapter 2 and follow the instructions in Chapter 3 so you can begin putting Edit Suite to work.

Chapter 2 • Overview of the Keyboard

This chapter provides an overview of Edit Suite's LCD and keyboard. Take a few minutes to familiarize yourself with the keyboard before proceeding with *Getting Started*. After completing the *Getting Started* chapter, review this chapter again for reinforcement.

LCD

The LCD (Liquid Crystal Display) is located in the upper middle of the top panel.

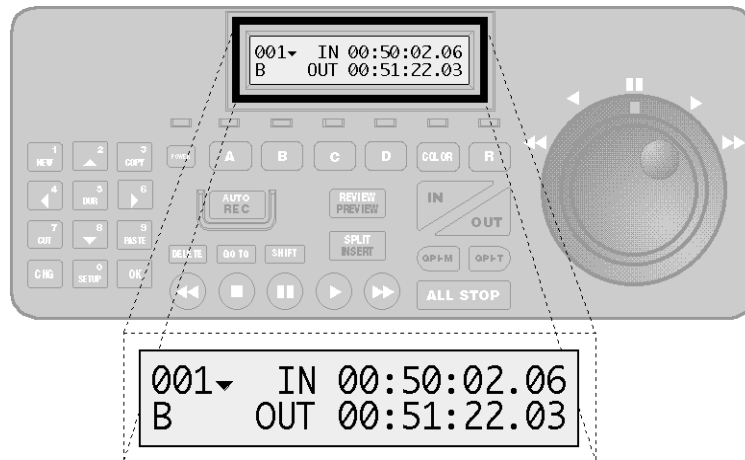

The information in the display changes when function keys are pressed, scenes are created, or VCRs are controlled. For example, the display above shows a Scene Event. Scene Events specify which VCR or camcorder contains the video for a scene (VCR "B" in this case), and the starting (IN) and ending (OUT) locations for the scene. The locations are shown in time-code format—hours:minutes:seconds.frames.

Another screen that is displayed often is the New Menu (below).

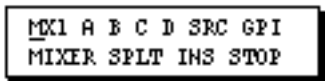

This menu provides one method of creating each type of event used with Edit Suite. To display the menu, press the NEW function key.

Function/Numeric Keypad

Located at the left side of the top panel are the twelve Function/Numeric keys.

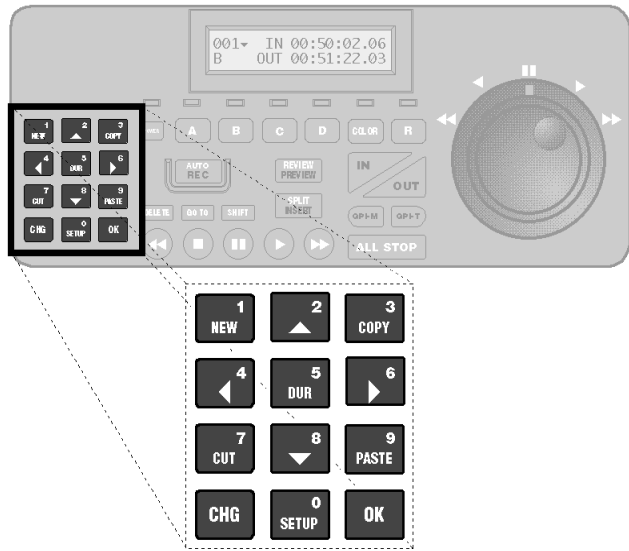

The function keys are used to add new events to a production, to cut, copy, and paste events that were created previously, and to display or change the duration of scenes. The arrow keys (keys 2, 4, 6 and 8) are used to move up, down, left, and right between fields and screens of information.

The change key [CHG] key temporarily switches the keypad to numeric-entry mode, the OK key confirms entries and clears messages, and the SETUP key accesses the Setup and Configuration menus. Always press [CHG] prior to entering data.

VCR/Source Selector Keys and LEDs

Located just below the LCD are six VCR/Source Selector keys and their associated LEDs (light emitting diodes).

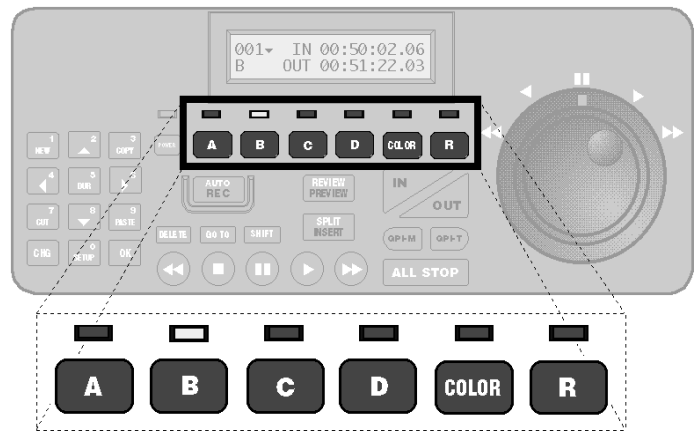

- Five of the six keys—A, B, C, D and R—are used to select the VCR to control. When a VCR is

selected, the LED above the selector key lights, indicating that you have control of that VCR.

If a Videonics MX-1 is attached to Edit Suite, pressing the A, B, C, or D key also changes the MX-1's output to the corresponding VCR.

- The sixth key—COLOR—is available to MX-1 users only, and is used to select COLOR as the MX-1's current source. This is often used to do fades to and from black.

The LEDs above the selector keys indicate which VCR Edit Suite will control when a transport key is pressed or the jog/shuttle is turned. There are four states for the LEDs:

1. If only one LED is lit, that VCR will be controlled.
2. If two LEDs are lit—one steady and one blinking slowly—the VCR with the steady LED is the *current* VCR and it will be controlled. The VCR with the blinking LED is the *next* source. If a mixer or switcher is attached, the next source is the "B" source in an A/B Roll.
3. If two LEDs are lit and one is flashing rapidly, that VCR is the "B" source in an A/B roll, and it will be controlled. (There is a key sequence you will learn later to make the *next* source controllable.)
4. If the "R" LED is lit, the record VCR will be controlled.

Production Keys

Located in the center portion of the top panel are the seven main production keys.

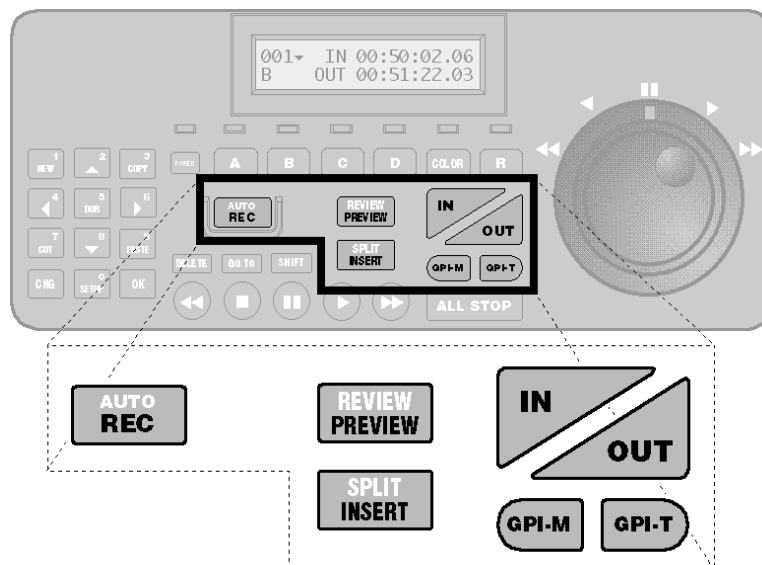

These keys are used primarily to create events, mark IN and OUT times for scenes, trigger mixers (GPI-M) and titlers (GPI-T), create Insert and Split Insert Events, and start an auto-record, preview or review of your production.

Transport Keys

Located at the bottom of the keypad are five Transport keys. They are, from left to right, Rewind, Stop, Pause, Play and Fast Forward.

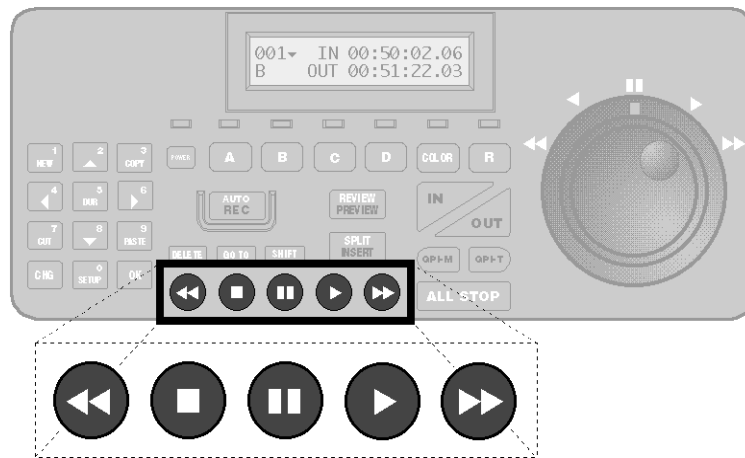

The Transport keys (and the jog/shuttle) are used to control the currently selected VCR (except Record VCRs using Infrared control).

Jog/Shuttle

The jog/shuttle is used to locate and mark the scenes you want to record. It can control all of your VCRs (except record VCRs using Infrared control), and it can be used for both rough and fine positioning.

The amount of control you get from the jog/shuttle depends on the capabilities of the VCR. If the VCR does not have any speeds between pause and play, then you will not be able to get them with the jog/shuttle. If, however, the VCR supports both frame-by-frame control and speeds as slow as 1/30th x Play, the jog/shuttle will provide this same level of control.

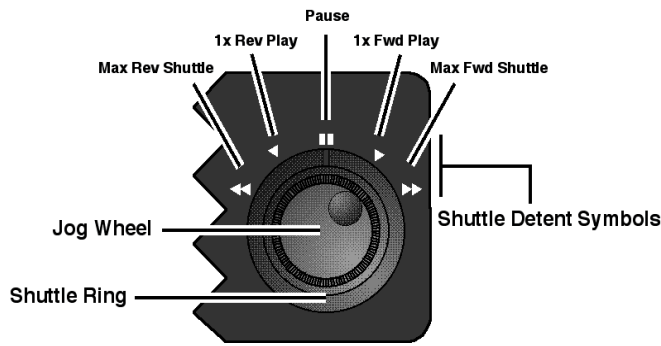

The Jog Wheel

For VCRs that allow frame-by-frame control, the jog wheel can advance or reverse the video one frame at a time. Depending on the VCR table you select (Appendix A), turning the jog forward at a slow speed will advance the video from three to seven frames per revolution. Turning the jog faster will advance the video at speeds ranging from $\pm 1/30$ th x Play to standard play speed.

Note: The jog can be used only when the shuttle is in the Pause position.

A secondary function of the jog/shuttle is to trim numeric values. As a general rule, anywhere you can make a numeric entry in Edit Suite, you can use the jog/shuttle to change that entry.

The Shuttle Ring

Again, depending on the capabilities of the VCR, the shuttle provides for forward and reverse control at speeds ranging from $\pm 1/30$ th x Play to speeds greater than ± 20 x Play. When the shuttle is turned you will feel detents at five locations. The center detent is Pause; the middle detents are Play and Reverse Play, and the outer detents are maximum forward and reverse shuttle.

ALL STOP

Located directly to the right of the Transport Control keys is the ALL STOP key.

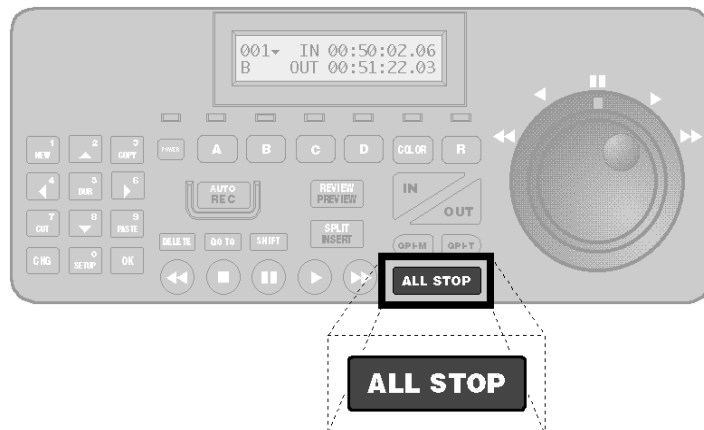

ALL STOP is used to stop the motion of all connected VCRs and camcorders. If an auto-record, preview, or review is in progress, it is terminated. Depending on the VCR, when ALL STOP is pressed the VCR will be placed either in STOP or in PAUSE.

Modifier Keys

Located below the AUTO REC key are three function modifier keys.

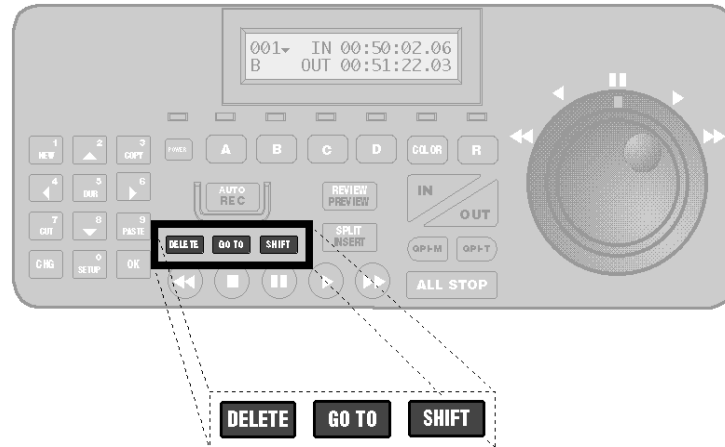

The Modifier Keys—Delete, Go To, and Shift—are used in combination with the Function, Selector, Production and Transport keys to access many of Edit Suite's functions. In all cases where two or three keys are required to access a function, the first one or two keys will be modifier keys.

When you see a reference to two or three keys, such as—

[SHIFT]+[UP ARROW] or

[GO TO]+[SHIFT]+[UP ARROW]

all keys must be pressed to start the function.

Modifier keys must be pressed and held down first, followed by the function key. In the first example above, press and hold the [SHIFT] key, then press the [UP ARROW] key. In the second example, press and hold both the [GO TO] and the [SHIFT] keys, then press the [UP ARROW] key.

Chapter 3 ◦ Getting Started

This chapter provides the information required to add Edit Suite to your existing setup, configure Edit Suite to work with your VCRs, and to create, preview and record a single-source and an A/B Roll production.

1. Check for Correct Edit Control Cables and GPI Cables

- Determine the type of Edit Control cable needed for each of your VCRs and camcorders—but do not attach the cables to Edit Suite yet. Your VCR/camcorder manuals and the figures below should help you determine which cables you need. (*Note the difference in pin positions between the Control-L 5-pin and the Panasonic 5-pin. These cables are not interchangeable.*)

Edit Suite comes with three Control-L submini cables, three Panasonic 5-pin cables and one IR (infrared) wand. If you need different or additional cables, follow the instructions on the Cable Exchange Card or contact the distributor in your country.

For customers with RS-232 or RS-422 VCRs who wish to make their own cables, a cable pin-out chart is provided in Appendix B. Most RS-232 users will also need a 9-pin to 25-pin adapter and, for most RS-232 VCRs [except Panasonic], a null modem. These are available at any computer parts store.

- A stereo GPI (general-purpose interface) cable is provided to connect Edit Suite to your mixer or titler. If you have both a mixer and a titler, you will need a second GPI cable. This is a standard stereo mini-jack to stereo mini-jack cable available from most audio or computer parts stores, from your Videonics dealer, or direct from Videonics.



Edit Suite to Sony LANC (Control-L Submini)



Edit Suite to Sony LANC (Control-L 5-pin)



Edit Suite to Panasonic 5-pin (Control-M)



Edit Suite to RS-232/422 (DB-9)



Edit Suite IR to Infrared Wand (mounted near VCR's IR window)



Edit Suite GPI-M/GPI-T to Mixer/Switcher/Titletler GPI

2. Set Up and Test VCRs/Mixer/Titletler Without Edit Suite

- Edit Suite will be an add-in to your existing video editing setup, so if you have a mixer or switcher, set up your equipment (VCRs, camcorders, titletlers and monitors) as described in your mixer/switcher manual.
- If you do not have a mixer, connect the audio and video outputs from your play VCR/camcorder to the corresponding inputs on your record VCR (via a titletler, if applicable). Connect the audio and video outputs from the record VCR to the inputs on your monitor. Make sure both the monitor and the VCR are set to receive audio and video inputs.
- Verify that your sources display, play and record as expected. If you have any problems, refer to Appendix C, Equipment Hookup.

3. Connect Power to Edit Suite

- Connect the Edit Suite power supply to the POWER input jack (back panel of Edit Suite) and plug the power supply into a working power outlet. Edit Suite will turn on, run through its startup routine, and then display either the New Menu or the Demo messages (shown below).

The Demo is a scrolling list of Edit Suite's features. The list will play over and over again, so move to Step 4 whenever you are ready.



New Menu



Demo: Scrolling Feature List

Note: If you have used Edit Suite previously and created any events, either the Demo or the first event in your list will display.

4. Display the Configuration Menu

Before Edit Suite can control your VCRs, it needs to know the type of VCR that will be attached to each VCR Control Port, the type of time code (RCTC, VITC, LTC) – if any – that will be used, and other information that customizes the way Edit Suite communicates with each VCR. You specify this information by selecting a VCR port to configure and then entering values in configuration parameters.

Start by displaying the Configuration Menu –

- A. Press  to display Setup Menu 1.

```
LCD_CONFIG NEWVCR
IMPORT EXPORT CMX ▼
```

Setup Menu 1

```
VCRA VCRB VCRC VCRD
VCRR GPI-M GPI-T
```

Configuration Menu

- B. Press  to move the cursor to CONFIG.



- C. Press  to display the Configuration Menu.

The Configuration Menu is used to select the VCR or GPI ports to configure and to display the parameters for that port. VCRA is used to configure Edit Suite's VCR Control Port A, VCRB configures VCR Control Port B, and so on. VCRR configures the Record VCR, GPI-M configures the GPI-M port, and GPI-T configures the GPI-T port.

5. Select and Configure the VCR Ports

- If you have a mixer or switcher, Edit Suite's VCRA port must match the mixer's input A or input 1; VCRB must match the mixer's input B or input 2, and so on. VCRR is for the record VCR.
- If you are not using a mixer/switcher, configure VCRR for your record VCR and any of the other ports for your source VCR(s).

To configure the ports –

A. Press  and  to move the cursor to the VCR port you want to configure, then –

press  to display the first screen of Configuration Parameters for that port.

```
VCRA VCRB_VCRC VCRD
VCCR GPI-M GPI-T
```

Configuration Menu

```
PROTO=NONE
VCR=001 PREROLL=0b▼
```

Configuration Parameters

B. Use the information below to determine and set the values for the PROTO, VCR, TCSRC and TC parameters.

PROTO **Type of control protocol.** Your choice here should match the type of cable you identified in Step 1. The choices are:

NONE	Either this port is not used, or a noncontrollable source—such as a live camera—is connected to the corresponding port on your mixer/switcher. In either case, no cable is attached to this Edit Suite control port and no other parameters need to be specified for this port.
IR	Infrared is used (record VCR only [VCRR]).
LANC	Sony LANC (Control-L) protocol is used.
PANA	Panasonic 5-pin (Control-M) protocol is used.
232	RS-232 protocol is used.
422	RS-422 protocol is used.

To select a protocol, with the cursor in the PROTO field press  repeatedly to cycle through the list of choices. Stop when the value you want is displayed.

If RS-232 protocol is selected, choices for baud rate and character format display. Check the manuals for your VCR to determine these values. To change values, press the left/right arrow keys to move the cursor to the field, then press [CHG] repeatedly until the correct choice is displayed.

NOTE: If your record VCR uses IR, after configuring all of your play VCRs, skip to Step 6.

VCR **VCR Table Number.** The table below lists several of the VCR numbers available with Edit Suite. Start with a value from this table. Additional VCR numbers and detailed descriptions are listed in Appendix A.

PROTO	VCR #
LANC	001 for VCRs (121 if RCTC is used*)
	002 for Camcorders (122 if RCTC is used*)
	007 for CCD-V5000 (124 if RCTC is used*)
	012 for Canon (125 if RCTC is used*)
	* if RCTC is used, the time code may not be passed to Edit Suite during Rewind or Fast Forward. If your VCR/camcorder counter goes blank or skips values during Rewind or Fast Forward, use these table numbers.
PANA	001 for VCRs and Camcorders
232	001 for Sony; 005 for UVW-1400
	003 for Panasonic
	004 for JVC
422	001 for VCRs with 1/30th X Play shuttle speed
	002 for VCRs with 1/10th X Play shuttle speed
IR	Skip to Step 6.

To enter a VCR table number, use the left/right arrow keys to move to the VCR field, then press [CHG] once. The cursor will change to a blinking block and the numeric keys on the keypad are activated. Type the three-digit value from the table. After the last digit is entered, the blinking cursor reverts to an underline and the keypad reverts to its non-numeric functions. If you make a mistake, press [CHG] again and reenter the number.

No change to the PREROLL value is needed at this time.

To display the next group of parameters, press . One of the following will display.

TCSRC=INT TC=NONE ▲
 ▼

VCRA ... VCRD

TCSRC=INT TC=NONE ▲
 INS=0 SPLT=0 ▼

VCRR

TCSRC **Time Code Source.** Specifies whether time code—if used—is sent via the Edit Control Cable or via an audio or video cable attached to Edit Suite's Time Code IN jack.

Choices are INT (internal: sent through the edit control cable) and EXT (external: sent through an audio or video cable). INT should be used in all cases except when LTC or VITC time

code will be delivered via a cable attached to a Time Code IN jack. If time code is not used, select INT.

To change the TCSRC choice, use the arrow keys to move to the TCSRC field and press [CHG].

TC Time Code Type. Specifies the type of time code – if any – that will be used. The choices are NONE, RCTC, VITC and LTC. If you are not sure if you have time code, select NONE for now. You can change this choice later.

To change the TC choice, use the arrow keys to move to the TC field and press [CHG] until the correct time-code type is displayed.

The INS (insert) and SPLT (split insert) parameters (record VCR only) do not need to be set now. However, if you know that your record VCR supports insert editing, you can change the value for INS to 1 now by pressing [CHG]. If it also supports split inserts, change that value to 1, too. Your VCR Operating Manual should indicate if your VCR has these capabilities.

Advanced Parameters

C. Verify that the advanced parameters for the port you are defining are set to the values below. If not, change them to these values.

PLY	Play Threshold (set to 00:15)
REW	Rewind Threshold (set to 00:30)
FFD	Fast Forward Threshold (set to 02:00)
STABLE	Stable Period (set to 45)

These parameters determine how Edit Suite searches for scenes when you preview or record your production.

To access the advanced parameters, press the down arrow enough times to skip past the offset parameters and display the ADVPARAMS screen, then press [OK].

To change the advanced parameters, use the arrow keys to move to the desired field, press [CHG] once, then type in the new value.

If you make a mistake that you notice before you have finished entering a value, press [CHG] twice: the first press erases your change and cancels change mode; the second press reactivates change mode. Remember, the cursor must be a flashing block before you can use the number keys.

If you inadvertently press SETUP before you are done, you are returned to the ADVPARAMS screen. Press [OK] again to redisplay the advanced parameters.

- D. Press [SETUP] twice. Edit Suite will configure the VCR port you just defined and return you to the Configuration Menu. While the port is being configured, a wait indicator displays in the lower, right corner of the display.
- E. Repeat Step 5 for all other VCR ports you will be using.

6. Configure and Test a Record VCR With IR Control

IR works for the record VCR only. If your record VCR uses IR Control, complete this step. Otherwise, skip to Step 7.

In this step, you will determine what command takes your VCR to Record from Record Pause (Pause, Play or Record), how to position the IR wand, and how to find the correct VCR number to control your VCR.

- A. If you have not already done so, select PROTO=IR by moving the cursor to the PROTO field and pressing [CHG] until the IR choice is displayed. The display will look similar to the one shown below.

```
PROTO=IR    CMD=PAUSE
VCR=001     PREROLL=0
```

In later portions of this step you will need to enter values in two fields: VCR and CMD. VCR is the Edit Suite table number that controls your VCR. CMD is the command your VCR uses to move the deck from Record Pause to Record.

- B. Press [SETUP] to save your choice and return to the Configuration Menu.
C. Unplug the power supply from Edit Suite.
D. Plug the IR wand into the IR jack on the back panel of Edit Suite (next to the POWER jack).
E. Position the IR Wand near the IR window on your record VCR.

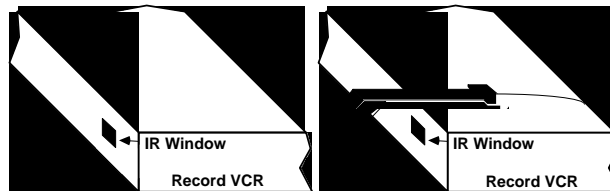

- F. Determine which command your record VCR uses to change from Record Pause to Record: Pause, Play or Record. (Pause is used by most VCRs.) To do this, load a blank tape into your record VCR, put the VCR into Record Pause, then press the Pause button on your VCR or remote control. If the VCR goes into Record, then this is the command to use in the CMD field in Edit Suite. If the VCR does not go into Record, try the Play and Record commands. Stop the recorder after you determine the command to use.
- G. Reconnect power to Edit Suite. After the demo begins or the NEW Menu displays, reselect VCRR by –
- pressing [SETUP] to display the Setup Menu

- moving the cursor to CONFIG and pressing [OK]
 - moving the cursor to VCRR and pressing [OK].
- H. Refer to the IR Table in Appendix A to determine the VCR table numbers that work with your brand of VCR. If your brand of VCR is not listed in the table or if you have already tried the VCR table numbers that are listed for your brand, skip to Step M.
- I. Use your VCR's control panel or remote control to put your record VCR into Record.
- J. Move to the VCR field, press [CHG] to activate the numeric keys, then enter one of the three-digit VCR numbers from Step H.

PROTO=IR	CMD=PAUSE
VCR=001	PREROLL=0

- K. **IMPORTANT:** Do this step even if the CMD field is already set correctly. Edit Suite needs to build the commands for you to test, and it will not do this until the value in the CMD field is changed, you press [SETUP], or you do the procedure in Step M.
- Move to the CMD field and press [CHG] enough times to display the command used to put your VCR into Record from Record Pause. (This is the command you determined in Step F.)
- L. Make sure the recorder is still in Record, then press Edit Suite's PAUSE –  – transport key. This will send a command to the VCR telling it to change to Record Pause.
- If the VCR goes into Record Pause, then the table number is correct and your VCRR configuration is complete. Move to Step 7.
 - If the VCR does not go into Record Pause, repeat Steps J, K, and L for the other VCR codes you determined in Step H.
 - If you have tried all the codes you determined in Step H, continue with Step M.
- M. If none of the VCR codes listed in Appendix A worked for your VCR, use the automatic IR test feature of Edit Suite.
- Change the VCR number to 001, set the CMD field to the correct command value, and ensure your VCR is still in Record.
 - Test Table 001 by pressing Edit Suite's PAUSE transport key. If the VCR goes into Record Pause, table 001 is the correct table. Skip to Step 7.

- Press Edit Suite's Fast Forward (>>) transport key. Edit Suite will build table 002, automatically change the VCR field value to 002, then send the Record Pause command to your VCR.
 - If the VCR pauses, the table number is correct and you are done with your IR setup.
 - If the VCR does not pause, continue pressing Edit Suite's Fast Forward transport key until you find a table that does work.

7. Configure the GPI-M Port

- A. Return to the Configuration Menu, select GPI-M, and press [OK]. The GPI-M configuration screen will display.

```
VCRA VCRB VCRC VCRD
VCCR _GPI-M GPI-T
```

Configuration Menu

```
GPI-M = _MX-1
```

GPI-M Configuration Screen

- B. Press [CHG] to cycle through the three choices. Select MX-1 if you will be using a Videonics mixer, select MIXER if you will be using a third-party mixer or switcher, or select GPI if you will not be using a mixer. The MIXER and GPI choices have an associated offset value. Leave the offset value set to +0000 for now.
- C. Press [SETUP] twice to exit the Setup menus and return to the NEW Menu. (No changes to the GPI-T port configuration are required.)

```
MX1 A B C D SRC GPI
MIXER SPLT INS STOP
```

New Menu

8. Attach Cables and Power-On Equipment

- For each VCR port you defined in Step 5 (except for Record VCR's using IR Control), attach an edit control cable between the VCR/camcorder and the appropriate VCR Control port on Edit Suite (A, B, C, D, REC).
- If you specified EXT (external) in the TCSRC field for a port, you will need to attach an audio cable (LTC) or video cable (VITC) from your VCR/camcorder to the corresponding Time Code IN port on Edit Suite. This delivers the time code from your video tape to Edit Suite.
- If the record VCR uses infrared (IR) control and it is not already plugged in, unplug the power supply from Edit Suite, plug the IR wand into the IR jack, then reconnect the Power Supply. Position the wand near your record VCR's IR sensor as shown in Step 6.

- If you have a mixer or switcher, attach a GPI cable from the GPI-M port to the mixer.
- If you have a titler or other GPI device, attach a GPI cable from the GPI-T port to the titler.
- Power on all connected equipment.

9. VCR Control – Testing and Troubleshooting

A. Setup

- Load a prerecorded video tape into each of your configured VCRs.

If you specified that LTC or VITC time code would be used and EXT (external) was selected in the TCSRC (time code source field) field, ensure that the tape you load has been striped with LTC or VITC.

If you specified that LTC, VITC or RCTC time code would be used and INT (internal) was selected in the TCSRC field, ensure that your VCR is configured to send the type of time code you selected and that the tape has been striped with the selected time code.

- If your VCRs have a Master/Slave switch or menu setting, select Slave.
- If your VCRs have a Local/Remote switch, select Remote.

B. Test

For each VCR port you defined and connected (except for a record VCR with IR control) –

- Press Edit Suite's A, B, C, D, or R key to select the VCR/camcorder to test. The LCD changes to display the time code from the selected VCR.

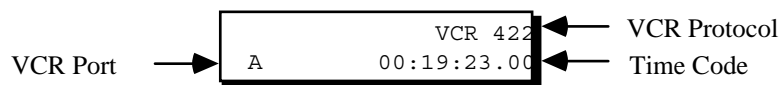

- Press the PLAY –  – transport key. The VCR should go into PLAY, and the time value should begin to increment. If it does, the PROTO, VCR, TCSRC and TC parameters are set correctly for this VCR and tape. Skip Step C and repeat the test for your other VCRs.

C. Troubleshoot

- For RS-232 and RS-422 VCRs, press the VCR selector key (A, B, C, D or R), then press [SHIFT]+[the STOP transport key]. This will send a reinitialization command to your VCR.
- For RS-232 VCRs, verify the baud rate and character format parameters. If these are correct, check your control cable for a null modem. If one is

- attached, remove it and try again. If one is not attached, add one and try again.
- If you get an error message (LTC NOT FOUND or VITC NOT FOUND), you specified LTC or VITC as the time-code type, but Edit Suite could not find the time code on your tape.
 - Advance to a different portion of the tape and try again, or try a different tape.
 - Verify that TCSRC=INT is selected if time code is sent through the Edit Control Cable (most RS-232 and RS-422 VCRs only), or that TCSRC=EXT is selected if the time code is sent by an audio or video cable attached to the Time Code IN port.
 - If the VCR can send multiple types of time code, ensure the correct type is being sent.
 - If the above do not work, change the configuration settings for this port to TCSRC=INT and TC=NONE to see if Edit Suite can read the Real Time Counter for the VCR.
 - If the VCR does not go into PLAY or if the time code displays as **:**:**:**, first verify that the control cable is attached to the correct port and VCR, that power is applied to the VCR, and that there is a tape with video in the VCR.
 - Next verify that the PROTO, VCR, TCSRC, and TC fields are set correctly. If not, correct them and try again.
 - For all VCRs, if you selected VITC, LTC or RCTC time code, change your settings to TCSRC=INT and TC=NONE to see if Edit Suite can control your VCR with the Real Time Counter.
 - Check Appendix A for additional VCR table numbers and try one of them.
 - If the Time Code displays as 00:00:00.00 and does not move, you probably have RCTC selected but no time code on the tape. Verify if the RCTC exists on the tape. If not, use the VCR's PLAY WRITE function to add the RCTC to the tape.
 - Some VCRs – like the Sanyo GVR-S955 – require a special cable. Refer to Appendix B for the cable pinout requirements.

10. Creating, Previewing and Recording an A/A Roll

- All of the configuration information you entered earlier and the scenes you are about to create are saved as soon as they are entered, so you can take a break at any time, remove power from Edit Suite [if necessary], then reapply power and resume where you left off.

- A. **SELECT A SOURCE TO USE:** Press the A, B, C or D key for one of the sources you were able to control. (The A, B, C, and D keys are called the VCR Selector keys.)
- B. **POSITION THE TAPE:** Use the jog/shuttle or transport keys to move the tape at least 45 seconds or one minute from the start of the tape.
- C. **CREATE A SCENE EVENT:** Press and hold the [SHIFT] key, then tap the [IN] key. A Scene Event for the current source is created (left figure). This is the first event in your EDL (Edit Decision List). "001" is the event number; "A" is the VCR port. The time is the time that was current on the VCR when [SHIFT]+[IN] was pressed.

001	IN	00:05:22.04
A	OUT	: : .

- D. **ADJUST THE IN TIME:** Use the transport keys or the jog/shuttle to move the tape to a new location. While you do this the Scene Event is replaced by the Live VCR display. The Live Display shows the current source and the current time code. (If you want to see the Scene Event again, press [OK].)

VCR PANA	
A	00:05:24.00

Live VCR Display

001	IN	00:05:24.00
A	OUT	: : .

Scene Event

Press [IN]. Edit Suite updates the value in the IN field to the VCR's current time.

- E. **ADD AN OUT TIME:** Move to an end position for the scene and press [OUT]. Edit Suite adds the current tape address to the OUT field of the active event.

001	IN	00:05:24.00
A	OUT	00:05:35.20

- F. **CREATE A SECOND EVENT:** Press [SHIFT]+[IN] again to create a second event. Adjust the IN and OUT times by positioning the tape and pressing [IN] or [OUT].
- G. **SEARCH TO A POINT ON THE TAPE:** This step has nothing to do with creating an A/A Roll, but it's a function you should know exists. You can have Edit Suite search to the IN or OUT point of any event by displaying the event and pressing [GO TO]+[IN] or [GO TO]+[OUT]. Try it.

H. **DISPLAY THE FIRST EVENT IN THE LIST:** Move to the first event in the list (the top of the EDL) either by pressing the up arrow several times or by pressing [GO TO]+[up arrow].

I. **PREVIEW THE SCENES:** Press [PREVIEW]. Edit Suite will –

- blink the POWER LED and turn off the other LEDs
- rewind the tape in your source VCR to a position in front of your first scene
- cue the tape to move closer to the scene
- play until five seconds from the scene, then beep once to alert you that your scene is about to start
- play your scene, beeping at the start of the scene and again at the end of the scene.

Next, Edit Suite will display the second event in the LCD, and repeat the above steps. After all scenes are complete, Edit Suite will beep three times, stop blinking the POWER LED, and resume displaying/blinking the ABCD LEDs.

J. **RECORD THE SCENES:** Load a tape in the record VCR. If your recorder uses 422 protocol, follow the instructions in your VCR manual to prestripe black on the tape, then position the tape about one minute (or more) from the start. If your recorder is IR-controlled, put the VCR in Record Pause.

Press [GO TO]+[up arrow] to return to the first event, then press [SHIFT]+[AUTO REC] to start recording. Again, the POWER LED will blink and the other LEDs will be turned off. Edit Suite will beep once five seconds before each scene, then three times when the auto-record is completed. You can abort an auto record or a preview at any time by pressing [ALL STOP] or the [Stop] transport key.

NOTE: *If you inadvertently pressed [REC] instead of [SHIFT]+[AUTO REC], the record VCR was started and a new event was created. This is called an Assemble Edit and is described in Chapter 4. Press [ALL STOP] to stop all VCRs, press [OK] to display the newly created event, then press [DELETE]+[CUT] to delete the event. After the event is deleted, repeat Step J.*

After the record is complete, press [ALL STOP] to stop the VCRs. ALL STOP will not stop an IR-controlled VCR. You will have to take it out of Record-Pause manually.

If you do not have a mixer or switcher or if you have only one source VCR, this concludes the *Getting Started* section. Review Chapter 2, then read Chapters 4 and 5 to learn about assemble and auto-assemble editing and each type of event that can be used with Edit Suite. To add accuracy to your edits, read Chapter 7, *Fine Tuning*.

11. A/B Rolls – For Users With a Mixer or Switcher

- A. **DISPLAY THE LAST EVENT IN YOUR EDL:** Press [down arrow] until the second event you created is displayed, or press [GO TO]+[down arrow].
- B. **CREATE A SCENE EVENT FOR A DIFFERENT SOURCE:** Press the VCR Selector key for one of your other sources, play that source to locate a section of video to record, then press [SHIFT]+[IN] to create a new event.

Assuming you only had two events in your EDL, the new event is assigned Event number 003.

- C. **ADD THE OUT TIME TO THE NEW EVENT:** Use the jog/shuttle or transport keys to move to the end of the video for the new scene and press [OUT].

You now have three completed scenes in your EDL. All that is required to create an A/B Roll is to add an MX1 or a MIXER Event between the last two scene events.

- D. **DISPLAY EVENT 002:** Use the up/down arrow keys to display the "A" event for the A/B Roll. This should be event 002.
- E. **ADD AN MX1 OR MIXER EVENT:** Press GPI-M (underneath the OUT key). Depending on how you configured the GPI-M port in Step 7, either an MX1 or a MIXER Event will be created between the last two scene events. Your EDL should look similar to one of these lists.

001	IN	00:05:22.04
A	OUT	00:05:35.20

002▼	IN	00:07:05.12
A	OUT	00:07:17.00

002/003	FX=001	DI=>
MX1	SP=5	BG=0 BC=

003▲	IN	00:22:22.01
B	OUT	00:22:45.10

001	IN	00:05:22.04
A	OUT	00:05:35.20

002▼	IN	00:07:05.12
A	OUT	00:07:17.00

002/003	TRANS	DUR
MIXER	00:00:03.00	

003▲	IN	00:22:22.01
B	OUT	00:22:45.10

The arrows on events 002 and 003 indicate that these events are part of a logical group. In this case, the group is scene event 002, the MX1 or MIXER transition, and scene event 003.

In the MX1 Event, FX is the MX-1 transition number, DI is the direction, SP is the speed, BG is the background color, and BC is the border color. A blank for a border color indicates that a border is not used. The speed determines the duration of the transition; this information is preprogrammed in Edit Suite. When the scenes are recorded, Edit Suite automatically sets up the MX-1 for the correct *current* and *next* sources.

In the MIXER Event, you need to specify the duration of the transition in seconds and frames. You do this by moving the cursor to the Duration field, pressing CHG, typing the duration or turning the jog until the correct duration is displayed, then pressing [OK]. For a cut to a new source without a transition, specify a duration of 00. For a transition to a new source, play the transition on your mixer, measure the duration for the transition as accurately as possible, then enter the duration in the MIXER Event. Also, you will need to ensure that the *current* and *next* sources are set correctly at the mixer before the transition is run.

- F. **PREVIEW THE A/B ROLL:** Display the last event in the EDL, then press [PREVIEW]. Because you were on the last event when PREVIEW was selected, only the last group of events will be previewed: scene 002, the transition, and scene 003. To preview the entire EDL, move to the top of the EDL before selecting PREVIEW.
- G. **RECORD THE A/B ROLL:** Display the scene event from which you want to start the recording, then press [SHIFT]+[AUTO REC]. Remember, if you are using a third-party mixer, you will have to set up your mixer sources manually. Also note that previews and auto-records always begin from the first event in the current group. (If there are no events related to the current event, it is a group consisting of a single event.) The only ways to record scene 003 (above) by itself is to separate it from its current group by removing the MX1 or MIXER event, or by adding a STOP event after the MX1/MIXER event.

After the auto-record is complete, press [ALL STOP].

This concludes the *Getting Started* section. Review Chapter 2, then read Chapters 4 and 5 to learn about assemble and auto-assemble editing and each type of event that can be used with Edit Suite. To add accuracy to your edits, read Chapter 7, *Fine Tuning*.

Chapter 4 • Making a Production

There are two primary methods of making productions with Edit Suite: assemble editing and auto-assemble editing.

In assemble editing, you start by making a rough recording of your production. Press [REC] at the start point for each scene and press [OUT] at the end time for each scene. Each time you press [REC], Edit Suite creates a new Scene Event and fills in the scene's IN time. Each time you press OUT, Edit Suite pauses the recorder and fills in the OUT time for the event. After the rough recording is complete, so is the first pass of the EDL.

Auto-assemble editing is the method used in Chapter 3, *Getting Started*, where you create Scene Events for each scene you want in your production, add the MX1 or Mixer Events between the scenes, and then press [SHIFT]+[AUTO REC] to have Edit Suite automatically assemble the production. You can also add other events, such as GPI Events to trigger a titler or character generator, STOP Events to pause a preview or auto-record, and INSERT and SPLT (split insert) Events to replace audio and/or video on a prerecorded tape.

This chapter describes the steps to do assemble and auto-assemble editing. It also provides instructions for reviewing the last recorded scenes, and provides hints to help improve your productions.

Assemble Editing

Before beginning an assemble edit, you should have a rough idea of which scenes you want to record and the order in which you want them to appear in your production. The scenes may all be from one source tape, or you can use several sources.

If you have multiple source tapes but only a single play VCR, use the NEW menu to add a STOP event each time you need to change tapes. This way, if you later auto-assemble the production, Edit Suite will pause the assembly whenever the tape needs to be changed.

Edit Suite does not preroll the VCRs during an Assemble Edit, so if your record VCR requires a preroll (usually, this applies to RS-422 VCRs only) there will be glitches between each scene. If you later do an auto-assemble edit of the same scenes, the glitches will be removed since an auto-assemble with an RS-422 as the record VCR prerolls the recorder.

To create an Assemble Edit—

1. If you are not using time code (RCTC, VITC, LTC), rewind your play VCRs/camcorders and reset the counters before you begin marking scenes.

For VCRs/camcorders using PANA or LANC protocol, you can have Edit Suite do this by pressing [GO TO] +[0 (zero)]. (Zero is the SETUP key.) For most VCRs using RS-232 or RS-422 protocol, Edit Suite will rewind the tape but not rezero the counter.

2. Manually place the record deck into Record Pause. (Use Play Pause for RS-422 VCRs.)
3. Press the VCR selector key (A, B, C, D) for the source you want to record.
4. Use the jog/shuttle or the transport keys to locate the scene you want to record.
5. Position the tape a few seconds before the scene and press the [PLAY] transport key.
6. At the start of the scene, press [REC].

Edit Suite will put the record VCR into Record. It will also create a Scene Event and fill in the IN time with the time code that was current on the play VCR when REC was pressed.

001	IN	00:05:22.04
A	OUT	: : .

7. At the end of the scene, press [OUT].

Edit Suite will put the record VCR into Record Pause. It will also add the OUT time to the event.

001	IN	00:05:22.04
A	OUT	00:05:35.20

8. Repeat Steps 3 through 7 for any other scenes you want to record. Step 2 may be omitted if the next scene is from the same source.
9. After all scenes have been recorded/created, press [ALL STOP] to stop all VCRs/camcorders.

Auto-Assemble Editing

1. If you are not using time code (RCTC, VITC, LTC), rewind your play VCRs/camcorders and reset the counters before you begin marking scenes.

For VCRs/camcorders using PANA or LANC protocol, you can have Edit Suite do this by pressing [GO TO] +[0 (zero)]. (Zero is also the SETUP key.) For VCRs using 232 or 422

protocol, Edit Suite will rewind the tape but not rezero the counter.

2. Create your Scene Events by–

- pressing the VCR Selector Key (A, B, C, D) for the source
- positioning the videotape to the start of the scene and pressing [SHIFT]+[IN] to create the Scene Event and fill in the IN time
- positioning the videotape to the end of the scene and pressing [OUT] to fill in the OUT time.

Other methods of creating Scene Events are described in Chapter 5.

3. Create Source Events for noncontrollable sources–like live feeds from a camera or solid colors from the MX-1. Source Events are described in Chapter 5.

4. If you have a mixer or switcher and want to do an A/B Roll between some of your scenes (rather than a straight cut), add an MX1 or MIXER Event between the scenes. MX1 and MIXER Events are described in Chapter 5.

5. If you have a titler or other GPI device and want titles to play during some of your scenes, add GPI-T Events at the locations you want the titles. GPI Events are described in Chapter 5.

6. If you have multiple source tapes but only a single play VCR, add a STOP Event each time you need to change tapes. Edit Suite will pause the assembly each time the tape needs to be changed. STOP Events are described in Chapter 5.

7. In the EDL, use the up/down arrow keys to display the first event that you want to record.

8. If your record VCR uses IR protocol, put the recorder into Record Pause.

9. Press [SHIFT]+[AUTO REC]. Edit Suite will auto-assemble your production.

Reviewing the Last Scene

To review the last scene that was recorded, press [SHIFT]+[REVIEW]. Edit Suite will select VCRR so the transport keys and jog/shuttle can be used to control the VCR. It will then position the recorder a few seconds ahead of the last scene that was recorded and play that scene.

If the last scene that was recorded was an A/B Roll, the entire A/B Roll will be played.

You cannot do a review if the record VCR uses IR protocol.

Production Hints/Precautions

1. When you create a source or record tape, use SP speed. This will provide the best audio and video quality and the best editing accuracy.
2. When you create a source tape, record 45-60 seconds of black at the start of the tape. In normal use, Edit Suite cannot access scenes that start earlier than approximately 45 seconds from the start of the tape.
3. When you create a source tape, shoot lots of footage. It is easy to edit out the bad footage, but it is difficult to catch the exact frame you want if there is no usable footage around it.
4. If you have access to time code, use it. This will greatly improve the accuracy of your productions.
5. If you have time code, it must be continuous or errors may occur.
6. If you do not have time code, rewind your tapes and rezero the counter before marking any scenes. Rewind/rezero periodically as you are building the EDL.

Rewind and rezero again before beginning an auto-record.

7. If you have a mixer or a switcher, go easy on the number of A/B rolls you use. Most productions use cuts between a majority of the scenes, and a transition every so often for effect. See *Match Frame Edits* in the MX1 Events section of Chapter 5 for more information on A/B Rolls.
8. If you have a titler, make sure your titles are started early enough so that they finish scrolling before the scene ends. Otherwise, they may be "cut" in the middle of the scroll.

Chapter 5 ◦ The NEW Menu and Edit Suite Events

There are several methods of creating events with Edit Suite. Chapter 3 showed you some methods of creating Scene and MX1 or MIXER Events. The NEW Menu provides another method of creating each type of event.

This chapter starts by showing you how to display and use the NEW Menu to create events. The later sections describe each type of event in detail.

There are eight types of events that can be created with Edit Suite. These are –

- **Scene Events** Identify the VCR or camcorder (A, B, C, D) that contains the scene, and the starting (IN) and ending (OUT) location for the scene.
- **Sources Events** Allow video from noncontrollable sources (SRC) to be used in a production. Often used to include live video from a camera or video device or, in conjunction with the Videonics MX-1, to fade up from black.
- **MX1 Events** Used with the Videonics MX-1 to create A/B Rolls between any of the VCRs, camcorders, or other sources attached to the MX-1, or to create A/B Rolls between a source and an MX-1 Color. Also used to do AXA Rolls between scenes from a single video source.
- **Mixer Events** Used with third-party mixers or switchers to cut from one source to another, and to create A/B Rolls between any of the sources connected to the mixer.
- **GPI Events** Send commands to titlers, character generators, and other GPI (general-purpose interface) devices.
- **Insert (INS)** Replace audio or video in the middle of a previously recorded videotape with new audio and/or video segments, while keeping the rest of the production unchanged.
- **Split Insert (SPLT)** Allow audio to lead the video or video to lead the audio during an audio/video insert.
- **Stop** Pause a preview or auto-record; separate one production from another; calculate total running time for a production.

The NEW Menu

The NEW Menu (below) is used to create Edit Suite events.

```
MX1 A B C D SRC GPI  
MIXER SPLT INS STOP
```

You can display the NEW Menu at any time except when in the SETUP menus or when a Preview, Auto Record, or Review is in progress.

To display the NEW Menu, press [NEW] (numeric key 1).

An alternate method of displaying the menu is to press [SHIFT]+[NEW].

The difference between these two methods is the order in which Edit Suite places the new event. For example, assume you have already created the following two Scene Events, and that the second event—event 002—is showing in the Edit Suite display.

```
001 IN 00:05:22.04  
A OUT 00:05:35.20
```

```
002 IN 00:07:05.12  
A OUT 00:07:17.00
```

If you press [NEW] to display the NEW Menu, the new event will be added immediately after event 002. If you use [SHIFT]+[NEW], the new event will be added immediately before event 002, as shown below.

```
001 IN 00:05:22.04  
A OUT 00:05:35.20  
002 IN 00:07:05.12  
A OUT 00:07:17.00  
003 IN : : .  
A OUT : : .
```

NEW

```
001 IN 00:05:22.04  
A OUT 00:05:35.20  
003 IN : : .  
A OUT : : .  
002 IN 00:07:05.12  
A OUT 00:07:17.00
```

SHIFT+NEW

Note the numeric sequence for the event numbers in the right-hand column—001, then 003, then 002. When a new event is created, Edit Suite assigns the next available number to the new event without changing the numbers of previously-created events. This way, once you create an event, that event number will always contain the same information no matter where it is located in the list. During a preview or an auto-record, Edit Suite processes the events in the order they appear in the list—not based on their event numbers. If you want to, you can manually change the event numbers or you can issue a command to Edit Suite to have it automatically renumber all of the events. The procedure to do this is described in the *Renumbering all Events in the EDL* section of Chapter 6.

To create an event with the NEW Menu

1. Press [NEW] or [SHIFT]+[NEW] to display the NEW Menu.

<u>M</u> X1 A B C D SRC GPI
MIXER SPLT INS STOP

2. Use the left/right/up/down arrow keys to move the cursor to the event type you want to create.
3. Press [OK] to create the event. (See the following sections for a more detailed description of each type of event.)

To exit the NEW Menu without creating an event

- Press [NEW] again. The event that was being displayed when the NEW Menu was selected will be redisplayed.

Note: If there are not any events currently created, the NEW Menu will remain displayed until you do one of the following –

- create an event
- access the SETUP Menus
- use Edit Suite to select/control a VCR/camcorder attached to a configured VCR port.

Scene (A/B/C/D) Events

Scene Events are the most common events in an EDL and the most important ones. They identify which VCR contains the footage you want to record and the starting and ending locations for that footage.

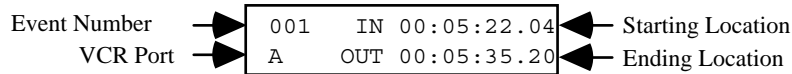

The starting location is called the Edit IN time; the ending location is called the Edit OUT time. Times are shown in an hours:minutes:seconds.frames format, with 30 frames per second in an NTSC system (North America, Japan) and 25 frames per second in a PAL system (Europe, Asia).

You can create an entire production with nothing more than Scene Events from a single source tape. Edit Suite will locate the first scene, record the video, cut to the second scene, record that video, and continue processing your Scene Events until they are all recorded.

If you have a Videonics MX-1 mixer, you can create Scene Events from two, three or even four different sources. Edit Suite will switch control from one VCR to the next when the video source changes, and it will automatically switch the output of the MX-1 to that same source. And still, the only events you need to create to do this are Scene Events.

If you have a third-party mixer or switcher, you will need to add a MIXER Event between your Scene Events when the video source changes from one VCR to another. See Mixer Events later in this chapter.

A/B Rolls? These depend on your Scene Events, too. To do an A/B Roll, you just create two Scene Events from different sources and put an MX1 or MIXER Event between the them.

Creating a Scene Event

There are three ways to create a Scene Event:

1. The NEW Menu

- Display the NEW menu, select A, B, C, or D—depending on which source has the video you want to add—then press [OK]. Edit Suite will make the VCR port you selected the *current* port, then create a Scene Event with empty IN and OUT times.

001	IN	:	:	.
A	OUT	:	:	.

The lights above the A, B, C, D keys are used to indicate which source is current. If only one light is lit – whether it is blinking or steady – that is the current source. If two LEDs are lit, the one that is steady indicates the current source.

2. Using the VCR Selector Keys

- Press [SHIFT]+[A], [B], [C], or [D]. Edit Suite follows the same procedure as if you create the event with the NEW menu.

3. Using the IN or OUT Keys

- A. If the source you want to use is not already the current source, press the [A], [B], [C] or [D] selector key.
- B. Press [SHIFT]+[IN] or [SHIFT]+[OUT]. A Scene Event for the current source is created with the IN or OUT time filled in (depending on which key you pressed).

001	IN_00:05:22.04
A	OUT : : .

SHIFT+IN

001	IN_ : : .
A	OUT 00:05:35.20

SHIFT+OUT

Completing/Changing the IN/OUT Times

When the Scene Events are created, either the IN time, the OUT time, or both times are empty. To fill in the IN/OUT times, either –

- Use the transport keys and the jog/shuttle to move the tape to the desired IN/OUT time and then press [IN] or [OUT]. If the time was already filled in, it is updated to the current time for the source.

or

- Move the cursor to the IN/OUT field, press [CHG] to activate the numeric keys, then type in the desired time code.

If you make a mistake before you have completed your entry, press [CHG] once to revert to the old value, press [CHG] again to reactivate the numeric keys, then re-attempt the entry.

If you enter, for example, 90 in the seconds field, it is automatically converted to one minute and 30 seconds.

Hints for numeric entry

1. If you have to change only one or two numbers in an existing time code, after pressing [CHG] you can move to a specific digit within the time code by pressing [SHIFT]+[left/right arrow]. Next, change the number and press [OK] to save your change.

2. You can always leave a numeric entry field before entering all the digits by pressing [OK]. If the remaining positions were blank, they are filled with zeroes. If the remaining positions were already assigned values, the old values are retained.
3. You can use the jog/shuttle to increment/decrement changes to the time code. To do this, press [CHG] to activate change mode, turn the jog/shuttle until the desired time is displayed, then press [OK]. The jog will work only if the shuttle is in the Pause position.

OUT Time Before IN Time

If you enter an OUT time that is earlier than your IN time, Edit Suite will beep twice when it saves the information. If you hear this beep, look carefully at the time codes you entered and correct the error.

If you do not correct the error, when you later attempt to preview or record the scene, Edit Suite will halt the preview or auto-record when it tries to process the event, and will display error message 01: *Out pt before in pt*. Clear the message by pressing [OK], then correct the error.

Adding Accuracy to the IN and OUT Times

Whether you use time code or not, the best tip for maintaining both accuracy and quality is to shoot all of your footage and record all of your productions using the SP tape speed setting on your camcorder or VCR.

If you have time code (VITC, LTC or RCTC), as long as the time-code data remains readable, your scenes will be accurate.

If you do not have time code, there are two procedures to follow to help maintain accuracy.

- Rewind the source tapes and rezero the VCR counter before you mark any scenes, and repeat the rewind/rezero procedure periodically while you are marking scenes. For VCRs and camcorders using PANA or LANC protocol, pressing [GO TO]+[zero] will rewind the tape for the selected VCR and rezero the counter. Pressing any key while the rewind/rezero procedure is in progress will abort the procedure.
- Unless your VCR displays frames along with its hours, minutes and seconds information, mark your scenes while the VCR is in Play speed. If a scene is marked while the video is playing, Edit Suite can interpret the time between each second to arrive at a frame value—even though the VCR doesn't provide any frame information.

If the tape is played at a jog or slow shuttle speed, the counter on the VCR does not increment (or does not increment accurately) so Edit Suite cannot estimate which frame value to use. Consequently, the time code will be recorded as hours, minutes, seconds, and 00 frames.

Refer to Appendix D, *Edit Control Chart*, for more information about time code and edit accuracy.

Changing the VCR Port

If you need to change the VCR port for a Scene Event, use the arrow keys to move the cursor to the VCR Port field, then press [CHG] enough times to display the desired port – A, B, C or D.

Event Number	→	001	IN	00:05:22.04
VCR Port	→	A	OUT	00:05:35.20

Changing the Event Number

If you want to change the Event Number for a Scene Event, use the arrow keys to move the cursor to the Event Number field, press [CHG] to activate the numeric keys, then type in the desired number (or use the jog/shuttle and press [OK]).

The number may be any three-digit value from 001 through 999. If there is already another event with the number you enter, Edit Suite will beep once and redisplay the old event number.

You can have Edit Suite renumber all of your events automatically by pressing the key combination [GO TO]+[SHIFT]+[CHG]. Renumbering events from 1 to the end is often called Ripple Down. Chapter 6 provides more information on the renumbering function.

Source (SRC) Events

Source Events are used to record video from noncontrollable sources, such as color bars from a pattern generator, live scenes from a video camera or background colors from the Videonics MX-1.

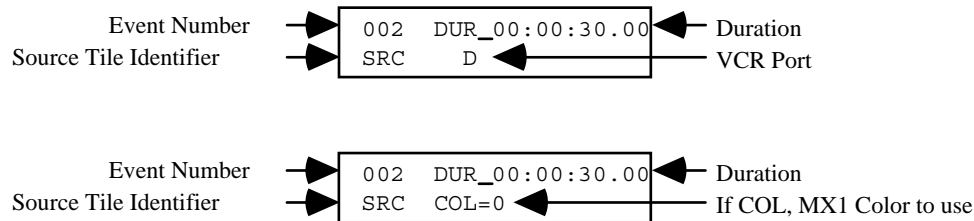

Because the sources are noncontrollable, there is no time-code entry. Instead, you specify a duration for the event.

Generally, Source Events are used only by customers who have a mixer or switcher. You connect the audio/video feeds from the source to your mixer and define the corresponding port on Edit Suite as `PROTO=NONE`. No cables are connected between the device and Edit Suite. At the appropriate time in your production, Edit Suite will send a command to the mixer/switcher to transition or cut to the source, and will then record or preview the video from that source for the specified duration.

Fade Up From Black

If you use a Videonics MX-1, you can access the MX-1 background colors via a Source Event. You specify the color you want to use and the duration of the scene, and Edit Suite will send commands to the MX-1 at the appropriate time to transition to or from the color. A Source Event is often used in combination with an MX1 Event at the start of the production to record a fade up from black. To do this, create a Source Event with `COL=0`, add an MX1 Event with `BC=0`, and follow with a Scene Event. The background color you select for the Source Event and the background color you select for the MX1 Event must be the same.

SRC Events Without a Mixer/Switcher

Without a mixer or switcher you cannot automatically cut from your play source to a noncontrollable source. However, if you add a STOP event each time you want to switch from one source to another, Edit Suite will pause your recording when it detects the STOP event. This way – with the recorder paused – you can change which device is connected to the recorder and then resume the production by displaying the next event to be recorded and pressing `[SHIFT]+[AUTO REC]`.

SRC Event Precaution

If the first event in an auto-record is a SRC event and if the record VCR is not already in Record Pause, either put it into Record Pause manually before starting the auto-record or add two or three seconds to the duration for the event. This is why –

- Near the start of an auto-record Edit Suite issues a Record Pause command to the record VCR.
- A few moments later, Edit Suite asks the record VCR what mode it is in. Many VCRs respond that they are in Record Pause – even though they may still be transitioning from Stop to Record Pause.
- Having been told that the VCR is already in Record Pause, Edit Suite issues the Record command to begin recording – but because the recorder was not really in Record Pause, until it gets there and then processes the Record command, the first few seconds of video from the Source Event will not be recorded.

The amount of error varies from VCR to VCR, but is never more than about two or three seconds. The problem does not occur with Source Events that are not the first events in an auto-record, since the record VCR will already be in Record Pause.

Ways of Creating a Source Event

There are three ways of creating a Source Event:

1. The NEW Menu

- Display the NEW menu, select SRC, then press [OK]. Edit Suite will create a Source Event with COL=0 as the default.

002	DUR_	:	:	.
SRC	COL=0			

2. Using the VCR Selector Keys

- Press [SHIFT]+[A], [B], [C], or [D] for any port whose protocol is set to NONE. Edit Suite will create a Source Event for that source.

3. Using the COLOR Key (Videonics MX-1 users only)

- Press [SHIFT]+[COLOR]. Edit Suite will create a Source Event with COL=0.

Entering/Changing the DUR (Duration)

To change the duration of a SRC event:

- Move the cursor to the DUR field, press [CHG] to activate the numeric keys, then enter the desired duration.

or

- Move the cursor to the DUR field, press [CHG], use the jog/shuttle to increment/decrement the duration, then press [OK]. (Note that the jog cannot be used unless the shuttle is in Pause.)

Changing the VCR Port or MX-1 Color

To change the source, use the arrow keys to move to the VCR Port field, then press [CHG] repeatedly until the desired source is displayed. The choices are A, B, C, D and COL. COL (color) applies to Videonics MX-1 users only and is used to specify that an MX-1 background color will be used.

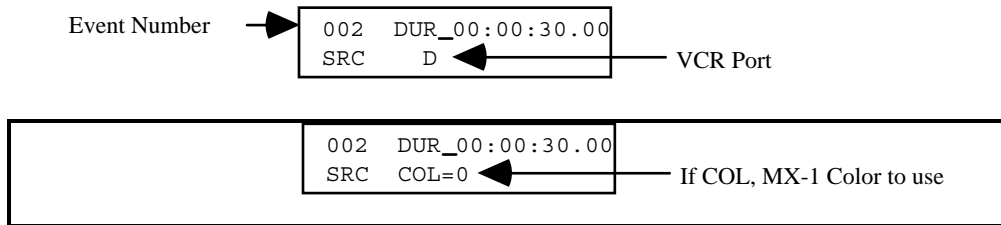

If COL is selected, you are also given a choice of which color to use. To change the choice for color, move the cursor to the color value field (0 above), press [CHG] and type the value. The values are the same as those used with the MX-1: 0=Black, 1=White, 2=Gray, 3=Red, 4=Yellow, 5=Green, 6=Bright Blue, 7=Light Blue, 8=Purple, 9=User-defined.

Changing the Event Number

To change the Event Number, use the arrow keys to move the cursor to the Event Number field, press [CHG] to activate the numeric keys, then type in the desired number (or use the jog/shuttle and press [OK]).

The number may be any three-digit value from 001 through 999. If there is already another event with the number you enter, Edit Suite will beep and redisplay the old event number that was assigned.

MX1 Events

MX1 Events are available to Videonics MX-1 users only. MX1 Events are used to create A/B Rolls between scenes from two play VCRs or AXA Rolls between scenes from the same VCR. In an A/B Roll, instead of cutting from one scene to the next, a fade, wipe, dissolve or other special effect can be used. During the transition from one source to the next, both sources are played, displayed and recorded simultaneously.

To specify an AXA Roll, add an MX1 Event between two scenes from the same VCR. Because both scenes are from the same VCR, a video freeze is done at the OUT point of the first scene, and the transition to the second scene begins from the frozen scene.

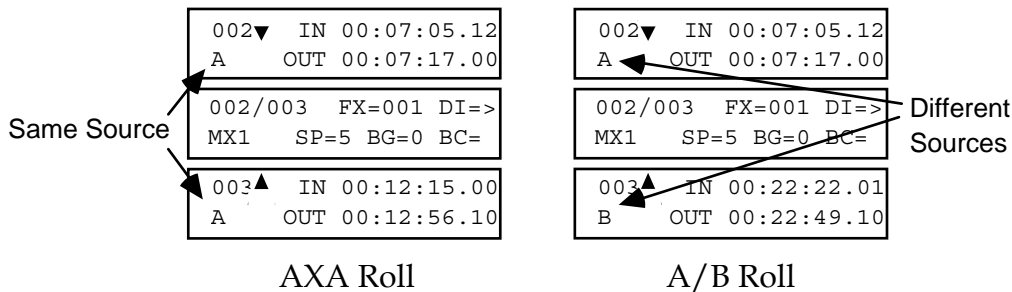

To specify an A/B Roll, add an MX1 Event between two Scene Events from different VCRs. In the above example, scene 002 is from VCR A and scene 003 is from VCR B.

The arrows on events 002 and 003 indicate that the events are part of a logical group. In this case, the group is the scene from event 002, the MX-1 transition, and the scene from event 003.

In the MX1 Event above, the event number – 002/003 – reflects the event numbers of both sources in the AXA and A/B Rolls. FX is the MX-1 transition number, DI is the direction for the transition, SP is the transition speed, BG is the background color, and BC is the border color. A blank for a border color indicates that a border color is not used.

When the above sequence is previewed or auto-recorded, Edit Suite sends commands to the MX-1 to tell it which source to make *current* and which to make *next*, and then sends all the transition information.

For A/B Rolls, the transition will be timed so that the midpoint of the transition is the OUT point for the "A" source and the IN point for the "B" source. You can adjust where the "B" source in an A/B Roll begins by changing the IN OFFSET parameter for the associated play VCR. Refer to Chapter 7, *Fine Tuning*, for more information.

For an AXA Roll, the only setup difference is that you place the MX1 Event between two scenes from the same source. For transition timing, the start point

of the transition in an AXA Roll is the OUT point for the first scene and the IN point for the second scene.

Match Frame Edits

Edit Suite does Match Frame Edits whenever back-to-back A/B Rolls are specified in the Edit Decision List.

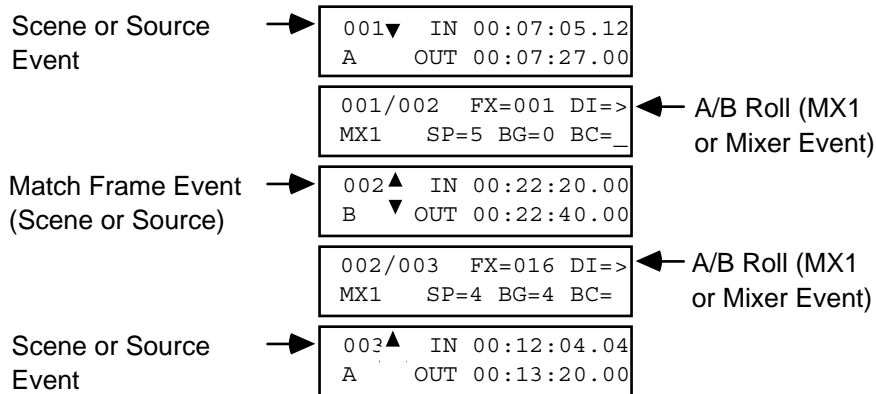

The above example instructs Edit Suite to do an A/B Roll between events 001 and 002, and then to do a second A/B Roll between events 002 and 003. For the first A/B Roll, event 002 is the "B" source for the roll; for the second A/B Roll, event 002 is the "A" source for the roll.

Before the first A/B Roll is done, Edit Suite synchronizes the video for events 001 and 002 by prepositioning the video for event 002 to its preroll position. This way, Edit Suite knows when to begin rolling the "B" source so that it will be playing the correct video when the MX-1 or Mixer transition occurs.

In order to do the second A/B Roll, the video for events 002 and 003 needs to be synchronized. Since the video from event 002 will already be playing, VCR B must be paused while the video for event 003 is located and positioned. The location where event 002 is paused is the Match Frame location.

To Edit Suite, event 002 is treated as two separate events: the first event has the same IN time as event 002; the second event has the same OUT time as event 002. The position where event 002 is paused – the Match Frame position – becomes the OUT time for the first half of event 002 and the IN time for the second half of event 002*.

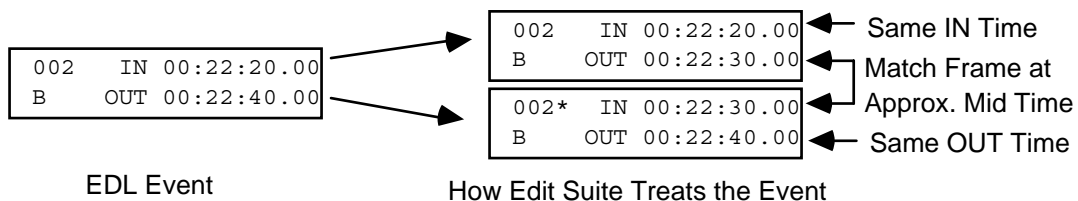

The Match Frame occurs at approximately the midtime of the scene, but may occur earlier or later depending on the duration of the scene and the speed or duration of the MX1 or MIXER Events.

Edit Suite will attempt to begin recording the second half of event 002 at the exact frame where the first half of event 002 ended; however, the match frame will only be as accurate as your VCRs and camcorders allow. If you have frame accurate VCRs and time code, the match frame can be exact so that in your final recording there are no missing or repeated frames around the match frame position. If your VCR/camcorders are not frame accurate, there may be a few frames of underlapping or overlapping video at the point of the match frame.

If your VCRs are not frame accurate, you can minimize the impact of any match frame error by manually splitting event 002 in the preceding example into two scenes and selecting a *match* point where there is non-critical video and a pause in the audio.

Simultaneous Rolling of Two VCRs

You can roll two VCRs simultaneously by placing an MX1 or MIXER Event between two Scene Events, leaving the OUT time for the second Scene Event blank, and pressing [PREVIEW] or [SHIFT]+[AUTO REC].

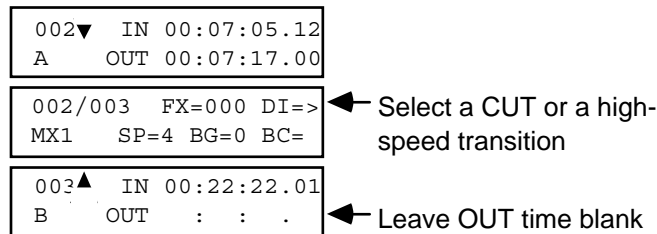

The OUT time for the first event and the IN time for the second event should be the positions where the video from the two sources needs to be synchronized. To fine-tune the point where the "B" source starts playing, adjust the IN OFFSET for the "B" source's VCR port as described in Chapter 7, *Fine Tuning*.

If you inadvertently fill in the OUT time for the second source, either delete the event and create a new one or change the OUT time to a high value – like 23:00:00.00.

Setup and Precautions

Before you can perform an MX-1 transition from Edit Suite, the GPI-M parameter in the CONFIG menu must be set to MX-1, and the MX-1 must be attached to Edit Suite's GPI-M port. Use the GPI cable provided with Edit Suite to connect the two devices. If a different cable is used, make sure it is a stereo cable.

If you are transitioning to or from an MX-1 Color, ensure that the color for the Source Event and the background color for the transition are the same.

If you specify a slow speed for a transition, ensure that your scenes are long enough to complete the transition before the scene ends.

Ways to Create an MX1 Event

There are two ways to create an MX1 Event:

1. The NEW Menu

- Display the NEW menu, select MX1, then press [OK]. Edit Suite will create an MX1 Event using the default values shown below.

002/003	FX=001	DI=>
MX1	SP=5	BG=0 BC=

2. The GPI-M Key

- Press GPI-M. An MX1 Event will be created using the field values that were selected on the MX-1 at the time the GPI-M button was pressed.

002/003	FX=187	DI=<
MX1	SP=4	BG=6 BC=4

If the event is placed between existing scene or Source Events, those events are used as the current and next sources for the transition. If the MX1 Event is placed after an last scene or Source Event in the EDL, Edit Suite will create a new Scene Event automatically. The *next* source on the MX-1 will be the source for the new event.

If the connection between Edit Suite and the MX-1 is not active (cable missing, MX-1 powered off, etc.) when the GPI-M key is pressed, an error message, *Error 21. No MX-1 found*, is displayed. Press [OK] to clear the error message, then complete the necessary connections.

Changing MX1 Event Fields

To change the MX1 Event fields:

002/003	FX=001	DI=>
MX1	SP=5	BG=0 BC=

- Move the cursor to the FX (transition number) field. Press [CHG] to activate the numeric keys, then enter the three-digit transition number. Any of the MX-1's 240 transitions (000-239) may be used.
- Move the cursor to the DI (transition direction) field. If you want to change the direction for the transition, press [CHG].
- Move the cursor to the SP (speed) field. To change the value, press [CHG] to activate the numeric keys, then use the numeric keys or the jog/shuttle to change the value. If you use the jog/shuttle, complete your entry by pressing [OK].
- Move the cursor to the BG (background color) field. To change the value, press [CHG] to activate the numeric keys, then use the numeric keys or the jog/shuttle to change the value.
- Move the cursor to the BC (border color) field. To change the value, press [CHG] to activate the numeric keys, then use the numeric keys or the jog/shuttle to change the value.

To specify that a border color will not be used, press [CHG], then press [DELETE].

Mixer Events

Use MIXER Events only if you have a third-party mixer or switcher attached to Edit Suite's GPI-M port.

Mixer Events are used to cut from one source to another and to create A/B Rolls between scenes from two play VCRs. In an A/B Roll, instead of cutting from one source to the next, a fade, wipe, dissolve or other special effect is used. During the transition between sources, both sources are played, displayed and recorded simultaneously.

To specify a cut to a scene from a new source, add a MIXER Event with a transition duration (TRANS DUR) of 00 between the two Scene Events. To specify an A/B Roll, add a MIXER Event between two Scene Events, and include the length of time it takes for the transition to run in the TRANS DUR field.

002▼	IN	00:07:05.12
A	OUT	00:07:17.00

002/003	TRANS DUR
MIXER	00:00:00.00

003▲	IN	00:22:22.01
B	OUT	00:22:45.10

Cut to New Source

002▼	IN	00:07:05.12
A	OUT	00:07:17.00

002/003	TRANS DUR
MIXER	00:00:03.20

003▲	IN	00:22:22.01
B	OUT	00:22:45.10

A/B Roll to New Source

The arrows on events 002 and 003 indicate that the events are part of a logical group. In this case, the group is the scene from event 002, the MIXER Event, and the scene from event 003.

In the MIXER Event above, the event number – 002/003 – reflects the event numbers of both sources in the Cut or A/B Roll. TRANS DUR is the length of time – in hours, minutes, seconds, and frames – that the transition will run. Edit Suite needs this information so it can determine the correct time to start playing the A/B Roll's "B" source and the correct time to send the transition command (GPI pulse) to the mixer/switcher.

To determine the transition duration, play the transition on your mixer at the speed you want to use and measure the length of time it takes to complete. If you have a window dub or a recording of a clock or stopwatch, you can record the transition and then subtract the end time from the start time. (Hint: Create a table of durations for the various transition speeds used by your mixer.)

An A/B Roll will be timed so that the *midpoint* of the transition is the OUT point for the "A" source and the IN point for the "B" source. You can fine-tune the starting time for the "B" source in an A/B Roll by changing the IN OFFSET

parameter for the associated VCR. This parameter is accessed from the Configuration Menu.

Before previewing or recording a cut or transition, you must manually set up or preprogram the mixer/switcher for the cut or A/B Roll's "A" source, "B" source, transition type, etc.

If you have a preprogramming feature to set up the sources and transitions, but you have too many transitions to store in your mixer/switcher memory, you can use Edit Suite STOP Events to break your production into two or more parts. See *STOP Events* later in this chapter.

For information about Match Frame Edits and Simultaneous Rolling of Two VCRs, refer to the MX1 Event description (previous section).

Setup and Precautions

Before you can run a MIXER transition from Edit Suite, the GPI-M parameter in the CONFIG menu must be set to MIXER.

The GPI-M MX OFFSET parameter is used to adjust the time Edit Suite sends the cut/transition command to the Mixer. If the cuts and transitions are always a little late, make the offset value larger. If they are always a little early, make the offset value smaller. The offset is in 1/8 frame increments, so a value of 0008 adjusts the timing by one frame. A value of 0240 (NTSC=8x30) or 0200 (PAL=8x25) adjusts the timing by one second.

The mixer/switcher must be attached to Edit Suite's GPI-M port. Use the GPI cable provided with Edit Suite to connect the two devices.

If a slow transition (long duration) is used, ensure that your scenes are long enough to complete the transition before the scene ends.

Ways to Create a MIXER Event

There are two ways to create a MIXER Event:

1. The NEW Menu

- Display the NEW menu, select Mixer, then press [OK]. Edit Suite will create a MIXER Event with a transition duration of zero (00).

002/003	TRANS DUR
MIXER	_00:00:00.00

2. The GPI-M Key

- Press GPI-M. A MIXER Event will be created with a transition duration of zero (00).

If the event is placed between existing scene or Source Events, those events are used as the current and next sources for the transition. If the

MIXER Event is placed after the last scene or Source Event in the EDL, Edit Suite will create the new event automatically. Edit Suite's *next* source will be the source for the new event. To set a *next* source, press [GO TO]+[A, B, C, or D].

Changing the MIXER Transition Duration

To change the MIXER Transition Duration:

002/003	TRANS DUR
MIXER	_00:00:00.00

- Press [CHG] to activate the numeric keys.
- Use the numeric keys or the jog/shuttle to change the value. If you use the jog/shuttle, complete your entry by pressing [OK].

GPI Events

Typically, a GPI (general-purpose interface) Event is used to send a trigger command to a titler or character generator. The titler will then play a screen of titles over your video footage before it is sent to the recorder.

Your titler, if you have one, should be connected to the GPI-T port on the back panel of Edit Suite. If you do not have a mixer or switcher, you can add a second titler or GPI device to the GPI-M port. If you do this, make sure you change your GPI-M choice in the CONFIG menu to GPI.

GPI Events are modifiers of your Scene and Source Events. As such, the event number for a GPI Event is the same as the Scene or Source Event it modifies, as shown below. If you change the event number for the Scene or Source Event, the GPI Event number is changed automatically.

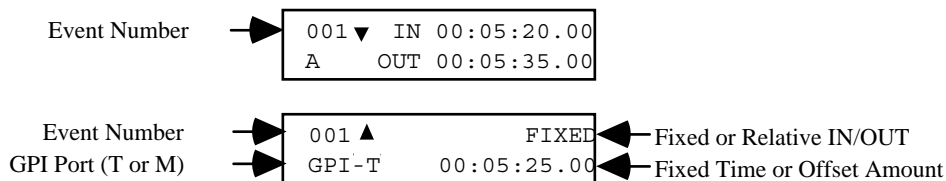

Notice the down arrow on the Scene Event and the up arrow on the GPI Event. The arrows are called grouping arrows and indicate that there are events (in this case the GPI Event) related to the Scene Event. Events that are grouped are called a logical event group.

If there were additional modifier events following the GPI Event, the GPI Event would have both an up and a down grouping arrow and the subsequent event would have an up arrow.

How Many GPI Events per Scene or Source

You can have up to 10 GPI Events associated with a single scene or Source Event. Edit Suite will not prevent you from adding more than 10 GPI Events; however, when it previews or records your production only the first 10 will be processed.

Fixed, Relative In, Relative Out

GPI Events can be sent at a fixed time code, at a time relative to the start of the associated scene (Relative In), or at a time relative to the end of the associated scene (Relative Out).

The following are three sample GPI Events, each using a different time reference, but each resulting in a GPI Event that would be sent at 00:05:25.00.

001 ▼ IN 00:05:20.00
A OUT 00:05:35.00

001 ▼ IN 00:05:20.00
A OUT 00:05:35.00

001 ▼ IN 00:05:20.00
A OUT 00:05:35.00

001 ▲	RELATIVE IN
GPI-T	+00:00:05.00

001 ▲	RELATIVE OUT
GPI-T	-00:00:10.00

001 ▲	FIXED
GPI-T	00:05:25.00

The Relative IN GPI is sent five seconds after (+00:00:05.00) the IN time of Scene 001 (05:20), so it is sent at 05:25. The Relative Out GPI is sent 10 seconds before (-00:00:10.00) the OUT time of Scene 001 (05:35), so it is sent at 05:25.

If the IN time for Scene 001 is changed, the Fixed and Relative Out GPIs are not affected, but the Relative In GPI will move with the scene's IN time. For example, if Scene 001's IN time is changed to 05:18.00 – two seconds earlier than the original IN time – the Relative In GPI would now be sent at 05:23.00.

If the OUT time for Scene 001 is changed, the Relative Out GPI Event is affected. For example, if the OUT time is changed to 05:40.00, the Relative Out GPI would be sent at 05:30.00.

The Fixed GPI Event will always be sent at the time specified – as long as that time is somewhere between the IN and OUT times for the scene. If it is outside the times for the Scene or Source Event, it will be ignored.

GPI Precautions

GPI Events should not be sent earlier than the IN time or later than the OUT time of the scene to which they are related.

GPI Events are usually used to send a trigger command to a titler or character generator. Typically, the titles can be timed to remain on the screen for just a few moments or for several seconds. If the title is still playing when Edit Suite pauses the record deck at the end of the scene, the remainder of the title will not be recorded.

For example, if you send a GPI Event five seconds before the OUT time for a scene, but the title that starts playing stays on the screen for 10 seconds, only the first five seconds of the title will be recorded.

If you have a mixer or switcher and use an A/B Roll between two sources, the record VCR will not normally be paused until the OUT time for the "B" source is reached. Because of this, your titles can be started near the OUT time for scene "A," be recorded over the A/B Roll, and continue while the "B" source is playing.

Note, however, that if you do an A/B/A Roll or an A/B/C Roll, Edit Suite will pause the recorder after the first transition in order to position the VCRs for the second transition. In this case, the titles must be finished at about the same time the first transition completes or they will continue to play while the record VCR is paused. See Match Frame Edits in the MX1 Events section of this chapter for more information about when the VCRs will pause.

Ways to Create a GPI Event

There are two ways to create a GPI Event:

1. The NEW Menu

- Display the NEW menu, select GPI, then press [OK]. Edit Suite will create an empty GPI Event.

```
001 ▲          FIXED
GPI-T         :  : .
```

2. The GPI-T Key

(or the GPI-M Key if the GPI-M port is configured for a GPI device)

- Press GPI-T. A Fixed GPI Event is created with the time code filled in. The time is the position of the *current* source when GPI-T was pressed.

```
001 ▲          FIXED
GPI-T         00:05:15.00
```

If the current source is different from the source for the active scene, a new Scene Event for the current source is also created. For example, the following Scene Event has a source of VCR Port A. If this scene is displayed in the LCD when you press GPI-T and VCR A is the current VCR, the GPI Event is the only event created.

```
001 ▼ IN 00:05:20.00
A     OUT 00:05:35.00

001 ▲          FIXED
GPI-T         00:05:25.00
```

If, however, VCR B is the current source, both a Scene Event for VCR B and the GPI Event will be created when you press GPI-T. The time in the GPI-T event will be the time that was current on VCR B when the GPI-T key was pressed. You will have to mark the IN and OUT times for the Scene Event.

```
002 ▼ IN 00:00:00.00
B     OUT  :  : .

002 ▲          FIXED
GPI-T         00:05:15.00
```

Changing the GPI Fields

To change the GPI fields:

GPI Port (T or M) →

```
001 ▲          FIXED
GPI-T         00:05:25.00
```

 ← Fixed or Relative IN/OUT
← Fixed Time or Offset Amount

- Move the cursor to the GPI-T/M field. Press [CHG] to change between GPI-M and GPI-T.

- Move the cursor to the FIXED field. Press [CHG] to cycle through the three choices: Fixed, Relative In, and Relative Out.
- Move the cursor to the TIME/OFFSET field. If you selected FIXED, press [CHG], then enter the time code for the event. If you selected RELATIVE IN or RELATIVE OUT, press [CHG], then enter the offset amount from the IN or OUT time of the related Scene or Source Event.

NOTE: If you selected RELATIVE IN or RELATIVE OUT, a sign field (\pm) precedes the offset. In most cases, you will use a (+) for a Relative In; in all cases you should use a (-) for a Relative Out.

Tuning GPI Events

If your GPI Events always start a little earlier or later than where you marked them, add an offset value to the GPI configuration parameter. The offsets are measured in 1/8 frame increments, so if the events start one frame late, add an offset of -0008. If they start one second late, add an offset of -0240 (NTSC=8x30) or -0200 (PAL=8x25).

Insert (INS) Events

Insert Events can be used only if the record VCR supports Insert Editing. Check your record VCR's operating manual to determine if it has this feature.

Insert Editing is the process of replacing some or all of the audio/video on a previously recorded tape with new audio and/or video. For example, if you created a 20-minute production but are not happy with the audio track between the 9th and 10th minute, you can replace that minute of audio without affecting the rest of the production.

To do this—

- Create a Scene Event to tell Edit Suite which source contains the replacement audio and where on that tape the audio is located.
- Create an Insert Event to tell Edit Suite where on the record tape the audio you want to replace is located.

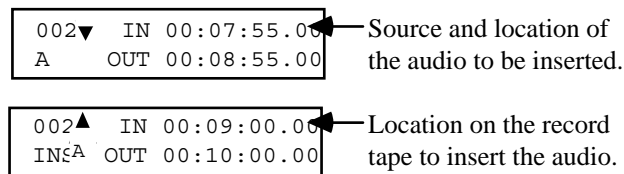

- If they are not already loaded, load the previously recorded tape in the record VCR and the tape with the new audio into the play VCR.
- Press [SHIFT]+[AUTO REC].

Edit Suite will send commands to the record VCR to position it at the insert point (or at the insert preroll point for some VCRs), position the play source at its preroll point, and then tell the record VCR to enter insert mode.

When both sources are ready, Edit Suite will roll the play source, sending both the audio and the video from that source to the recorder. Depending on the type of insert specified and the capabilities of the recorder, the recorder will record the audio only, the video only, or both the audio and the video.

Insert Events are always related to a Scene or Source Event, so grouping arrows are added to both events to show the relationship. The Insert Event is also assigned the same event number as the Scene or Source Event.

Types of Inserts

In the Insert Event above, the letters INS indicate that the event is an insert. The small "A" following INS indicates the type of insert to be done. There are three choices for the type of insert: Audio only (A), Video only (V), and Audio and

Video (AV). Which of these you can use depends on the capabilities of the record VCR. Note: There is no option for splitting Left and Right Audio.

Some VCRs only support video inserts; others support both audio inserts and video inserts, but not both at the same time, and so on. Read your VCR manuals carefully to determine the type(s) you can use.

Typically, an audio insert overwrites the PCM audio (CH1/2), a video insert overwrites the video and the AFM audio, and an audio/video insert overwrites the video, the AFM audio and the PCM audio. Again, check your Record VCR's operating manual for specifics.

Insert and Scene Event Times

Although it is best to complete the IN and OUT times for both the Scene Event and the INS Event, one of the OUT times may be omitted.

- If you omit the OUT time for the INS Event, Edit Suite will use the duration of the Scene Event to determine the duration for the insert.
- If you omit the OUT time for the Scene Event, Edit Suite will use the INS event's IN and OUT times to determine the duration of the insert.
- If all four times are specified, but the duration of the Scene Event is different from the duration of the INS Event, the duration of the INS event is used. If the Scene Event has a shorter duration, the OUT time for the Scene Event will be ignored and the source VCR will continue to play until the insert is complete.

Setup and Precautions

If possible, use VCRs that support time code to do your inserts. This will provide the best accuracy for locating the insert point and the audio/video to be inserted. If time code is not available, rewind both the play and record VCRs before marking the insert points, then verify and adjust the points by using the [GO TO]+[IN] and [GO TO]+[OUT] functions.

Before you can do an insert, you must set the INS parameter for VCRR (in the CONFIG Menu) to 1. This indicates to Edit Suite that the record VCR is capable of doing insert edits. If this is not done, during a preview or auto-record, Edit Suite will beep twice and display *Error Message 23: Insert not available* when the INS Event is encountered. The preview or auto-record will be halted at that time. Respond to the error message by pressing [OK], then make the necessary change.

If the inserts start or end a little early or late, adjust the InsIN and InsOUT offset parameters in the Configuration Menu for VCRR. The values are in 1/8 frame increments: a value of -0008 for the InsIN parameter starts the inserts one frame earlier; a value of -0240 (NTSC) or -0200 (PAL) starts the inserts one second earlier.

If the InsIN offset is greater than one or two seconds, you will need to increase the PREROLL time for the Scene Event's play VCR by a corresponding amount.

The best example of this is a record VCR that uses PANA protocol. Typically, a Panasonic 5-pin VCR advises Edit Suite that it is in insert mode (and it turns on its insert indicator) almost seven seconds before it actually begins recording the insert. During this time there is no counter or tape movement.

You must adjust for this "waiting" time by changing both the InsIN offset for the record VCR and the PREROLL value for the source VCR/camcorder. For PANA record VCRs, then, start with an InsIN offset value of -1608 (NTSC) or -1340 (PAL), and increase the PREROLL value for the play VCR from 5 to 12 seconds.

For other protocols, start with the InsIN default value of 0000 and leave the preroll value for the source VCR set to five seconds.

Ways to Create an Insert Event

There are three ways to create an Insert Event:

1. The NEW Menu

- Display the NEW menu, select INS, then press [OK]. Edit Suite will create an Insert Event with a default insert type of AV, and with empty IN and OUT times.

002▲	IN	:	:	.
INS▲	OUT	:	:	.

2. The INSERT Key

- Press INSERT. An Insert Event is created with AV as the insert type and with the IN time set to the current time from the Record VCR. The Record VCR is also selected as the current VCR so you can use the transport keys and the jog/shuttle to locate the IN and OUT times for the insert. Press [IN] to add/change the IN location; press OUT to add/change the OUT location.

3. The R Key plus IN or OUT

- Press R to select the record VCR.
- Use the transport keys to position the recorder to the IN or OUT point for the insert.
- Press [IN] or [OUT] to create the INS Event with the IN or OUT time filled in, depending on which key was pressed.

Changing the INS Field Values

To change the INS field values:

002▲	IN	00:09:00.00
INS ^A	OUT	00:10:00.00

- Move to the INS type field and press [CHG] repeatedly to cycle between the three choices: *AV* for both audio and video, *A* for audio only, *V* for video only.
- Use the IN/OUT keys (as described above) to update the IN and OUT times, or move to the field, press [CHG] to activate the numeric keys, then either type the value, or use the jog/shuttle to increment or decrement the value and press [OK].

Split Insert (SPLT) Events

Split Insert Events are modifiers of Insert Events and can be used only if your record VCR supports splitting of the audio and video inputs during Insert Editing. Check your VCR manual to determine if your VCR can do this.

If you have not already done so, read the previous section about Insert Events.

There are two choices for Split Inserts: Video Delay and Audio Delay. If you select Video Delay, an Audio Insert will begin at the location specified in the INS Event and, after the delay specified in the SPLT Event, both the audio and the video will be inserted. Typically, the delay is only a few seconds.

002▼	IN	00:07:55.12
A	OUT	00:08:55.12

002▲	IN	00:09:00.00
INS▲	OUT	00:10:00.00

002▲	VIDEO DELAY	
SPLT	00:00:03.00	

Setup and Precautions

A Split Event will not be processed by Edit Suite unless it immediately follows an Insert Event.

If a Split Insert is to be done, the INS type must be AV.

Before you can do a Split Insert, you must set both the INS and the SPLT parameters for VCRR (in the CONFIG menu) to 1. In combination, these indicate to Edit Suite that your record VCR is capable of doing Split Insert edits. If you do not do this, during a preview or auto record, Edit Suite will beep twice and display *Error Message 24: Split not available* when the SPLT event is encountered. The preview or auto record will be halted at that time. Respond to the error message by pressing [OK], then make the appropriate changes.

If the split starts or ends a little early or late, you can adjust the SPLT offset parameter in the Configuration Menu for VCRR. The value is in 1/8 frame increments, so use a value of -0008 for the SPLT parameter to start your split one frame earlier, or a value of -0240 (NTSC) or -0200 (PAL) to start your split one second earlier.

Ways to Create a Split Insert Event

There are two ways to create a Split Insert Event:

1. The NEW Menu

- Display the NEW menu, select SPLT, then press [OK]. Edit Suite will create a SPLT Event with a split type of video delay and a blank duration.

002▲	VIDEO DELAY
SPLT	: : .

2. The SPLIT Key

- Press [SHIFT]+[SPLIT]. If the active event (the event displayed in the LCD) is an Insert Event, a SPLT Event is created. If the active event is not an Insert Event, Edit Suite will beep twice and ignore the command.

Changing the SPLT Field Values

To change the SPLT field values:

002▲	VIDEO DELAY
SPLT	00:00:03.00

- Move to the Delay Type field and press [CHG] to cycle between the two choices: VIDEO DELAY and AUDIO DELAY. If you want the audio to start first, select VIDEO DELAY.
- Move to the time code field, press [CHG] to activate the numeric keys, then enter the amount of delay.

Stop Events

STOP Events are used to separate one production from another or to pause a production to allow you to change tapes, hookups, etc.

	TOTAL RT
STOP	00:15:24.00

The STOP Event shows the total running time for your production from the start of your first Scene or Source Event to the STOP Event or –if you have more than one STOP Event– from the previous STOP Event to the next STOP Event. The time is in the format hours:minutes:seconds.frames.

During a Preview or Auto Record, when Edit Suite encounters a STOP Event, it pauses the preview/record operation and beeps three times. To resume the operation, use the up/down arrow keys to display the next Scene or Source Event you want to preview/record, then press [PREVIEW] or [SHIFT]+[AUTO REC] again. Edit Suite will resume the preview/record and continue until it reaches the next STOP Event or the last event in your list.

One common use of STOP Events is to separate entire productions. Edit Suite can hold 250 events, which for many users is enough for several small productions. The STOP Event will give you the total running time for each of your productions, and it provides you with an easy method of moving quickly from production to production. The key combination [GO TO]+[SHIFT]+[up/down arrow] moves up or down in your list of events from one STOP Event to the next or to the top/bottom of the EDL if no more STOP Events are encountered.

Another common use of Stop Events is to bracket a series of scenes that you want to fine-tune. This way you can preview and test-record a small part of your production rather than the entire production.

A third use for customers who do not have a mixer or switcher is to add a STOP Event wherever you need to change source tapes.

Ways to Create a STOP Event

There is only one way to create a STOP Event:

- display the NEW menu
- move the cursor to STOP
- press [OK].

Chapter 6 • Managing The Edit Decision List

The Edit Decision List (EDL) is the collection of events you create with Edit Suite. Chapter 5 provides descriptions and instructions for creating each type of event used with Edit Suite. This chapter describes functions and key combinations that will help you manage the EDL. Included are procedures for–

- Moving up and down through the EDL
- Moving events from one location to another
- Creating copies of events
- Deleting some or all events
- Renumbering all events

To gain a working understanding of the procedures in this chapter, we suggest that you create a small EDL similar to the one shown below, then practice each procedure as you read through the chapter. This will make it easier for you to recall the procedures and key sequences when you need to use them for your own productions.

Moving Up and Down Through the EDL

In Step 10 of the *Getting Started* you created the first two events in your EDL. With only two events, it was easy to move from one event to the next by pressing the up and down arrow keys.

But a full EDL can contain up to 250 events. How can you move quickly to the top or bottom of the EDL? Or from one Scene or Source Event to the next? Or from one Stop Event to the next? This section describes the key combinations to do all of these, as well as providing a procedure to display a specific event.

To move to the top or bottom of the EDL–

From anywhere in the EDL, press [GO TO]+[up arrow] ...	or press [GO TO]+[down arrow].
---	--------------------------------

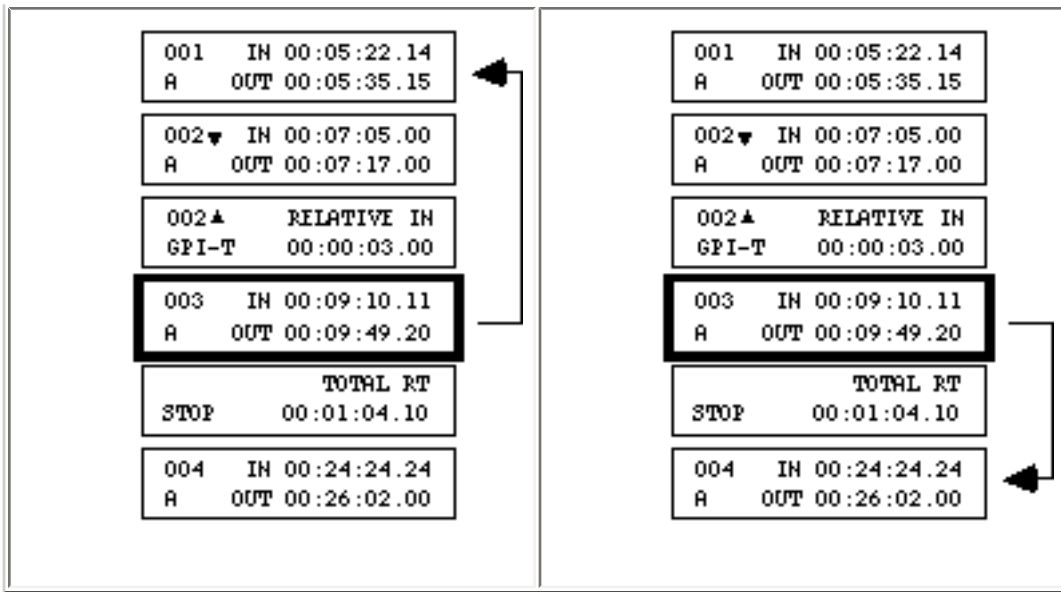

In the preceding example, event 003 is the active event (the event displayed in the LCD) when the GO TO+up/down arrow keys are pressed. The arrows indicate which event will display next.

You often move to the top of the EDL before doing a preview or auto-record so that all the events in the EDL are previewed/recorded.

You often move to the bottom of the EDL before adding new scenes. This way the new scenes are added after the existing scenes. Otherwise, new scenes are added after the active event.

To display the previous or next Scene or Source Event–

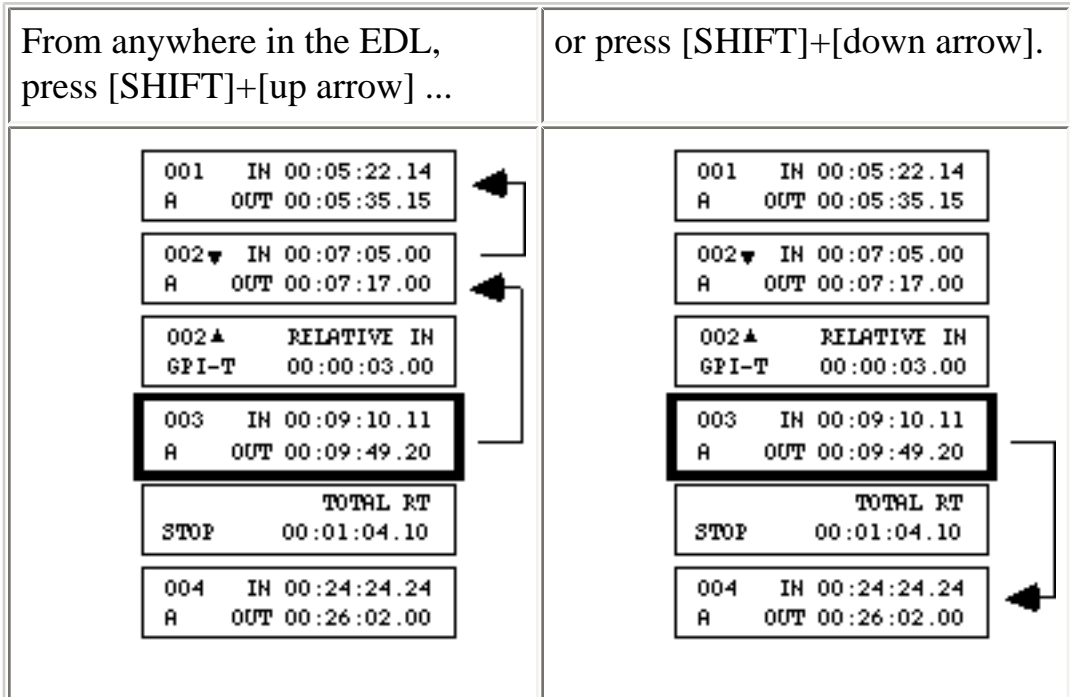

Each press of [SHIFT]+[up/down arrow] moves up or down to the previous/next Scene or Source Event. All GPI, MX1, MIXER, INS, SPLT, and STOP events are skipped.

To display the previous or next Stop Event–

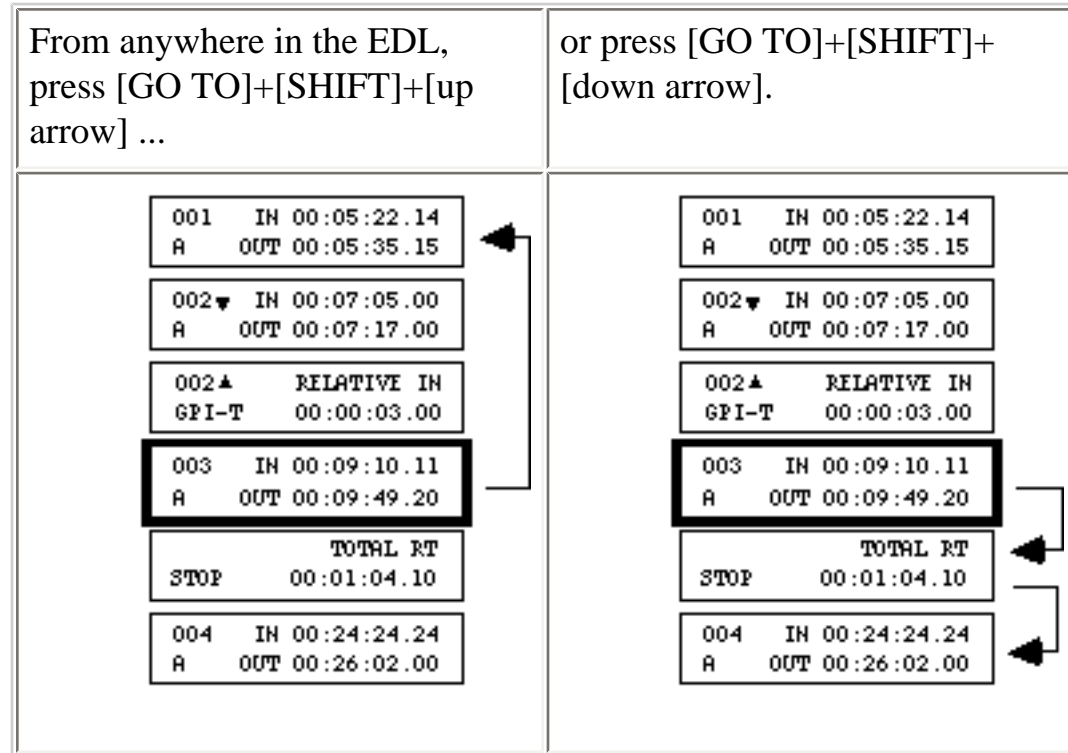

If there are no more Stop Events between the current event and the top/bottom of the EDL, the top/bottom event displays.

If you use Stop Events to separate your productions, the above key sequence provides an easy method of moving from one production to the next.

To display a specific event–

- Press [GO TO]+[OK] to display the Go To screen.

GO TO #000

- Press [CHG] to activate the numeric keys.
- Type the event number (leading zeroes do not need to be entered), then press [OK].
- If the event number exists in the EDL, that event is displayed.

- If the event number does not exist in the EDL, *Error 22: Invalid ED#*, displays. Press [OK] to clear the message.

- If the live tile (below) displays after you run this procedure, you were controlling a VCR when [GO TO]+[OK] was pressed. Press [OK] to display the event.

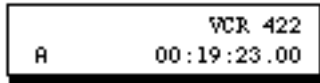

Moving Events

After previewing your production, you may find it necessary to move some events from one location to another. This section describes procedures for moving an individual event or a group of events.

To Move an Event From one Location to Another–

1. Display the event to be moved and press [CUT].	2. Display the new location for the "cut" event.	3. Press [PASTE].
<pre>001 IN 00:05:22.14 A OUT 00:05:35.15 002▼ IN 00:07:05.00 A OUT 00:07:17.00 002▲ RELATIVE IN GPI-T 00:00:03.00 003 IN 00:09:10.11 A OUT 00:09:49.20 TOTAL RT STOP 00:01:04.10 004 IN 00:24:24.24 A OUT 00:26:02.00</pre>	<pre>001 IN 00:05:22.14 A OUT 00:05:35.15 002▼ IN 00:07:05.00 A OUT 00:07:17.00 002▲ RELATIVE IN GPI-T 00:00:03.00 TOTAL RT STOP 00:00:25.01 004 IN 00:24:24.24 A OUT 00:26:02.00</pre>	<pre>001 IN 00:05:22.14 A OUT 00:05:35.15 003 IN 00:09:10.11 A OUT 00:09:49.20 002▼ IN 00:07:05.00 A OUT 00:07:17.00 002▲ RELATIVE IN GPI-T 00:00:03.00 TOTAL RT STOP 00:01:04.10 004 IN 00:24:24.24 A OUT 00:26:02.00</pre>

In the above example, Scene Event 003 is moved from its original location to a new location following event 001.

When [CUT] is pressed (Step 1), the event is deleted from the EDL and placed into a temporary storage

location, called the *paste buffer*. It remains in the paste buffer until [PASTE], [CUT] or [COPY] is pressed.

When [PASTE] is pressed (Step 3), the event is pasted after the active event. If [SHIFT]+[PASTE] is pressed instead of [PASTE], the event is pasted before the active event.

Caution: Each time [CUT] or [COPY] is pressed, any events already in the paste buffer are deleted before the new events are added. If you inadvertently press [CUT] a second time before pressing [PASTE], the event you wanted to move will be deleted.

Notice the order of the events in the third column. Event 003 retained its old event number instead of causing the entire list to be renumbered. This way, you can keep track of events by their original event numbers no matter where they are located in the EDL. If you want to renumber the events so that the event number matches the event's position in the EDL, press [GO TO]+[SHIFT]+[CHG].

To Move a Group of Events From one Location to Another–

1. Display any event in the group to be moved and press [SHIFT]+[CUT].	2. Display the new location for the "cut" group of events.	3. Press [PASTE].
<pre>001 IN 00:05:22.14 A OUT 00:05:35.15 002▼ IN 00:07:05.00 A OUT 00:07:17.00 002▲ RELATIVE IN GPI-T 00:00:03.00 003 IN 00:09:10.11 A OUT 00:09:49.20 TOTAL RT STOP 00:01:04.10 004 IN 00:24:24.24 A OUT 00:26:02.00</pre>	<pre>001 IN 00:05:22.14 A OUT 00:05:35.15 003 IN 00:09:10.11 A OUT 00:09:49.20 TOTAL RT STOP 00:00:52.10 004 IN 00:24:24.24 A OUT 00:26:02.00</pre>	<pre>001 IN 00:05:22.14 A OUT 00:05:35.15 003 IN 00:09:10.11 A OUT 00:09:49.20 TOTAL RT STOP 00:00:52.10 004 IN 00:24:24.24 A OUT 00:26:02.00 002▼ IN 00:07:05.00 A OUT 00:07:17.00 002▲ RELATIVE IN GPI-T 00:00:03.00</pre>

In the above example, the group of events that includes scene 002 is moved from its original location to a new location following event 004.

When [SHIFT]+[CUT] is pressed (Step 1), all the events in the group are deleted from the EDL and placed into a temporary storage location, called the *paste buffer*. They remain in the paste buffer until [PASTE], [CUT] or [COPY] is pressed.

When [PASTE] is pressed (Step 3), the entire group of events is pasted after the active event. If [SHIFT]+[PASTE] is pressed instead of [PASTE], the group is pasted before the active event.

Caution: Each time [CUT] or [COPY] is pressed, any events already in the paste buffer are deleted before the new events are added. If you inadvertently press [SHIFT]+[CUT] a second time before pressing [PASTE], the group of events you wanted to move will be deleted.

Notice the order of the events in the third column. Event 002 retained its old event number instead of causing the entire list to be renumbered. This way, you can keep track of events by their original event numbers no matter where they are located in the EDL. If you want to renumber the events so that the event number matches the event's position in the EDL, press [GO TO]+[SHIFT]+[CHG].

Copying Events

There may be occasions when you want to use the same event in more than one location in your production. This section provides procedures for copying individual events and groups of events and pasting the copies in a different location in your EDL.

To Make a Copy of an Event–

1. Display the event to be copied and press [COPY].	2. Display the new location for the copied event.	3. Press [PASTE].

001 IN 00:05:22.14 A OUT 00:05:35.15	001 IN 00:05:22.14 A OUT 00:05:35.15	001 IN 00:05:22.14 A OUT 00:05:35.15
002▼ IN 00:07:05.00 A OUT 00:07:17.00	002▼ IN 00:07:05.00 A OUT 00:07:17.00	005 IN 00:09:10.11 A OUT 00:09:49.20
002▲ RELATIVE IN GPI-T 00:00:03.00	002▲ RELATIVE IN GPI-T 00:00:03.00	002▼ IN 00:07:05.00 A OUT 00:07:17.00
003 IN 00:09:10.11 A OUT 00:09:49.20	003 IN 00:09:10.11 A OUT 00:09:49.20	002▲ RELATIVE IN GPI-T 00:00:03.00
TOTAL RT STOP 00:01:04.10	TOTAL RT STOP 00:01:04.10	003 IN 00:09:10.11 A OUT 00:09:49.20
004 IN 00:24:24.24 A OUT 00:26:02.00	004 IN 00:24:24.24 A OUT 00:26:02.00	TOTAL RT STOP 00:01:43.19
		004 IN 00:24:24.24 A OUT 00:26:02.00

In the above example, a copy of event 003 is placed after event 001. The copy is assigned the next available event number—005 in this case.

To place the new event before the active event, instead of pressing [PASTE], press [SHIFT]+[PASTE].

After [PASTE] or [SHIFT]+[PASTE] is pressed (Step 3), the paste buffer is empty. To make another copy of the event, repeat the procedure.

To Make a Copy of a Group of Events—

1. Display any event in the group of events to be copied and press [SHIFT]+[COPY].	2. Display the new location for the copied group of events.	3. Press [PASTE].
--	---	-------------------

001 IN 00:05:22.14 A OUT 00:05:35.15	001 IN 00:05:22.14 A OUT 00:05:35.15	001 IN 00:05:22.14 A OUT 00:05:35.15
002▼ IN 00:07:05.00 A OUT 00:07:17.00	002▼ IN 00:07:05.00 A OUT 00:07:17.00	005▼ IN 00:07:05.00 A OUT 00:07:17.00
002▲ RELATIVE IN GPI-T 00:00:03.00	002▲ RELATIVE IN GPI-T 00:00:03.00	005▲ RELATIVE IN GPI-T 00:00:03.00
003 IN 00:09:10.11 A OUT 00:09:49.20	003 IN 00:09:10.11 A OUT 00:09:49.20	002▼ IN 00:07:05.00 A OUT 00:07:17.00
TOTAL RT STOP 00:01:04.10	TOTAL RT STOP 00:01:04.10	002▲ RELATIVE IN GPI-T 00:00:03.00
004 IN 00:24:24.24 A OUT 00:26:02.00	004 IN 00:24:24.24 A OUT 00:26:02.00	003 IN 00:09:10.11 A OUT 00:09:49.20
		TOTAL RT STOP 00:01:16.10
		004 IN 00:24:24.24 A OUT 00:26:02.00

In the above example, a copy of the group of events that includes event 002 is being placed after event 001. The group is assigned the next available event number(s)—005 in this case.

To place the new group before the active event, instead of pressing [PASTE], press [SHIFT]+[PASTE].

After [PASTE] or [SHIFT]+[PASTE] is pressed (Step 3), the paste buffer is empty. To make another copy of the group, repeat the procedure.

Deleting Events and Event Contents

This section describes the procedure for deleting the contents of an event, as well as procedures for deleting—

- a single event
- a group of events
- all Stop Events in the EDL
- all GPI-T or GPI-M events in a group

- all GPI-T or GPI-M events in the EDL
- all events in the EDL

To Delete the Contents of an Event–

1. Display the event.
2. Press [DELETE]+[NEW].

The event remains, but the contents of the event are deleted and the default values–if any–are added. For example, in a scene event, the IN and OUT times are deleted.



To Delete an Event–

1. Display the event.
2. Press [DELETE]+[CUT] or press [CUT].

Pressing [DELETE]+[CUT] deletes the event without putting a copy of the event in the paste buffer. Pressing [CUT] deletes the event but puts a copy in the paste buffer so the event can be pasted to a new location. (See Moving Events earlier in this chapter.)

Note: If you delete the last remaining event in the EDL, Error Message 13, *EDL empty*, displays. Clear the message by pressing [OK]. The NEW menu (below) will display.

```

MX1 A B C D SRC GPI
MIXER SPLT INS STOP
    
```

To create a new Scene or Source Event, use the NEW Menu, the VCR Selector keys ([SHIFT]+[A, B, C or D]) or, if you have an MX-1, the COLOR key ([SHIFT]+[COLOR]).

To Delete a Group of Events–

1. Display any event in the group of events to be deleted.
2. Press [SHIFT]+[DELETE]+[CUT] or press [SHIFT]+[CUT].

Pressing [SHIFT]+[DELETE]+[CUT] deletes the group of events without putting a copy of the events in the paste buffer. Pressing [SHIFT]+[CUT] deletes the group of events but puts a copy in the paste buffer so the events can be pasted to a new location. (See Moving Events earlier in this chapter.)

To Delete all STOP Events in the EDL–

- Press [SHIFT]+[DELETE]+[ALL STOP].

To Delete all GPI-T or GPI-M Events in a Group of Events–

1. Display any event in the group.
2. Press [DELETE]+[GPI-T] or [DELETE]+[GPI-M].

To Delete all GPI-T or GPI-M Events in the EDL–

1. Display any event in the group.
2. Press [SHIFT]+[DELETE]+[GPI-T] or [SHIFT]+[DELETE]+[GPI-M].

To Delete all Events in the EDL–

1. Press [SETUP] to display SETUP Menu 1 (of 2).



LCD CONFIG MENU
IMPORT EXPORT CMD ▾

2. Press [down arrow] twice to display SETUP Menu 2.

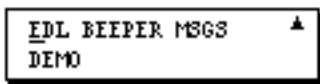

EDL BEEPER MSGS ▲
DEMO

3. Move the cursor to EDL (if it is not already selected) and press [OK]. The following message displays.

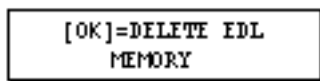

[OK]=DELETE EDL
MEMORY

4. To delete all events from the EDL, press [OK]. After a few moments, Setup Menu 2

redisplays.

Press [SETUP] to leave the Setup Menus and display the New Menu.

MX1 A B C D SRC GPI
MIXER SPLT INS STOP

NOTE: To cancel the delete function without deleting any events, press [SETUP] to return to the second Setup menu, then press [SETUP] again to return to the EDL.

Renumbering all Events in the EDL

After deleting, moving and copying events, the event numbers in the EDL will probably be out of a numerical sequence. Although this poses no problem for Edit Suite, you may want the event numbers to be in sequential order. To do this—

1. From anywhere in the EDL, press [GO TO]+ [SHIFT] +[CHG].	2. The events are renumbered in a numerical sequence.																																																								
<table border="1"><tr><td>001</td><td>IN 00:05:22.14</td></tr><tr><td>A</td><td>OUT 00:05:35.15</td></tr><tr><td>005</td><td>IN 00:09:10.11</td></tr><tr><td>A</td><td>OUT 00:09:49.20</td></tr><tr><td>002</td><td>IN 00:07:05.00</td></tr><tr><td>A</td><td>OUT 00:07:17.00</td></tr><tr><td>002</td><td>RELATIVE IN</td></tr><tr><td>GPI-T</td><td>00:00:03.00</td></tr><tr><td>003</td><td>IN 00:09:10.11</td></tr><tr><td>A</td><td>OUT 00:09:49.20</td></tr><tr><td colspan="2">TOTAL RT</td></tr><tr><td>STOP</td><td>00:01:43.19</td></tr><tr><td>004</td><td>IN 00:24:24.24</td></tr><tr><td>A</td><td>OUT 00:26:02.00</td></tr></table>	001	IN 00:05:22.14	A	OUT 00:05:35.15	005	IN 00:09:10.11	A	OUT 00:09:49.20	002	IN 00:07:05.00	A	OUT 00:07:17.00	002	RELATIVE IN	GPI-T	00:00:03.00	003	IN 00:09:10.11	A	OUT 00:09:49.20	TOTAL RT		STOP	00:01:43.19	004	IN 00:24:24.24	A	OUT 00:26:02.00	<table border="1"><tr><td>001</td><td>IN 00:05:22.14</td></tr><tr><td>A</td><td>OUT 00:05:35.15</td></tr><tr><td>002</td><td>IN 00:09:10.11</td></tr><tr><td>A</td><td>OUT 00:09:49.20</td></tr><tr><td>003</td><td>IN 00:07:05.00</td></tr><tr><td>A</td><td>OUT 00:07:17.00</td></tr><tr><td>003</td><td>RELATIVE IN</td></tr><tr><td>GPI-T</td><td>00:00:03.00</td></tr><tr><td>004</td><td>IN 00:09:10.11</td></tr><tr><td>A</td><td>OUT 00:09:49.20</td></tr><tr><td colspan="2">TOTAL RT</td></tr><tr><td>STOP</td><td>00:01:43.19</td></tr><tr><td>101</td><td>IN 00:24:24.24</td></tr><tr><td>A</td><td>OUT 00:26:02.00</td></tr></table>	001	IN 00:05:22.14	A	OUT 00:05:35.15	002	IN 00:09:10.11	A	OUT 00:09:49.20	003	IN 00:07:05.00	A	OUT 00:07:17.00	003	RELATIVE IN	GPI-T	00:00:03.00	004	IN 00:09:10.11	A	OUT 00:09:49.20	TOTAL RT		STOP	00:01:43.19	101	IN 00:24:24.24	A	OUT 00:26:02.00
001	IN 00:05:22.14																																																								
A	OUT 00:05:35.15																																																								
005	IN 00:09:10.11																																																								
A	OUT 00:09:49.20																																																								
002	IN 00:07:05.00																																																								
A	OUT 00:07:17.00																																																								
002	RELATIVE IN																																																								
GPI-T	00:00:03.00																																																								
003	IN 00:09:10.11																																																								
A	OUT 00:09:49.20																																																								
TOTAL RT																																																									
STOP	00:01:43.19																																																								
004	IN 00:24:24.24																																																								
A	OUT 00:26:02.00																																																								
001	IN 00:05:22.14																																																								
A	OUT 00:05:35.15																																																								
002	IN 00:09:10.11																																																								
A	OUT 00:09:49.20																																																								
003	IN 00:07:05.00																																																								
A	OUT 00:07:17.00																																																								
003	RELATIVE IN																																																								
GPI-T	00:00:03.00																																																								
004	IN 00:09:10.11																																																								
A	OUT 00:09:49.20																																																								
TOTAL RT																																																									
STOP	00:01:43.19																																																								
101	IN 00:24:24.24																																																								
A	OUT 00:26:02.00																																																								

Events are renumbered beginning with number 001.

Only Scene (A, B, C, D) and Source (SRC) Events are assigned unique event numbers. All other events relate to Scene or Source Events and are assigned the same event number as the scene/source to which they relate. An example of this is shown with the GPI Event, above.

When a STOP Event is encountered, the hundreds digit is incremented and the tens and units digits are reset to 01. For example, the first Scene or Source Event after the first STOP Event will be event 101 (as shown in Step 2, above); the first event after the second STOP Event will be 201, and so on.

If nine or more STOP Events are used to separate the EDL events, the hundreds digit is not incremented after any STOP Event: all scene and source events will be numbered in sequence. For example, if there were nine or more STOP Events in the above EDL, event 101 would be assigned event number 005.

Chapter 7 • Fine Tuning

After you have configured Edit Suite and recorded some scenes, you may find that the recorded scenes start or end a few frames early or late. If this is the case, use the IN and OUT OFFSET parameters to fine-tune Edit Suite.

Before Adjusting the Offset Parameters

If you do not have time code (VITC, LTC or RCTC) available, before you begin marking scenes or adjusting parameters, rewind the videotape and reset the VCR counter to zero. Repeat the rewind and rezero procedure periodically while you are marking scenes—especially if there has been a lot of back-and-forth movement of the videotape. This will minimize the amount of "slippage" that occurs over time in the VCR's transport.

Use Edit Suite's GO TO - Zero function (select the VCR then press [GO TO]+[0]) to rewind the tapes. For VCRs with PANA and LANC protocols, this function will also rezero the counter.

Tape speed is also important in deck tuning. The best speed to use for video and audio quality and for editing accuracy is SP. Be consistent with the speed you select.

Preparation

To begin the fine-tuning procedure, create an EDL with three events.

If you have a Videonics MX-1, make the first event an SRC event with a 10-second duration and COL=0 (black), make the second event a scene with a duration of approximately 10 seconds, and make the third event another SRC event with a 10-second duration and COL=0.

001 DUR 00:00:10.00 SRC COL=0	001 IN 00:05:22.04 A OUT 00:05:35.20
002 IN 00:07:05.12 A OUT 00:07:17.00	002 IN 00:07:05.12 A OUT 00:07:17.00
003 DUR 00:00:10.00 SRC COL=0	003 IN 00:05:22.04 A OUT 00:05:35.20

If you do not have an MX-1, create three scene events from the same source each with a duration of

approximately 10 seconds.

In both cases, the first and the third events are "don't care" events for VCR fine tuning. The IN and OUT locations for the second event are the important locations. With this in mind, when you select the IN and OUT points for the second event, select a scene that is easily identifiable, such as a car passing a street sign or a door slamming shut. If you have a window dub (a tape recorded with a time code readout displayed on the video), use it.

Play VCRs OUT OFFSET

The first parameter to verify is the OUT OFFSET for each of the play VCRs—A, B, C and D. The OUT OFFSET is used by Edit Suite to determine when it needs to send a Pause command to the VCR so that the player pauses at the correct time.

Note: For VCRs whose PROTO= 232 or 422 AND whose TCSRC=INT, this parameter is not used. These VCRs control their own searches.

To determine if the Out Offset needs to be adjusted—

1. Use the up/down arrow keys to display the second EDL event.
2. Press [GO TO]+[IN] to have Edit Suite search for the IN time for the second event.
3. When the VCR pauses, press [OK] to redisplay the EDL.
4. Determine the direction of error.

- If the VCR paused at the position you marked for the IN time, no adjustments are necessary. Change the source for the Scene Events to the next source, switch the videotape to that source, and repeat steps 1-4 for all other play VCRs.

- If the VCR paused before the position for the IN time, the value for the Out Offset is too large and needs to be decreased.

- If the VCR paused after the position for the IN time, the value for the Out Offset is too small and needs to be increased.

5. Determine the amount of error.

Error is measured in frames. There are 25 frames per second in a PAL (Europe, Asia, Middle East, Australia) system and 30 frames per second in an NTSC (US, Canada,

Japan) system.

Depending on the type of VCR or camcorder you are using, you can measure the amount of error accurately by turning the jog knob slowly, watching the monitor carefully, and counting the number of frames that change. Turn the knob clockwise if Edit Suite paused too early, or counterclockwise if it paused too late.

If your VCR or camcorder does not have jog capabilities, estimate the number of frames of error.

If you have a window dub and you know the dub time that equates to the IN time for your scene, you can calculate the difference in frames.

6. Determine the change to the offset value.

Offsets are measured in 1/8 frame increments. Multiply the amount of error you determined in Step 5 by eight. (For example, five frames of error times eight is 40.) This is the amount of change you should make to the play VCR's OUT OFFSET parameter.

7. Add or subtract the value in Step 6 to the current OUT OFFSET value, then repeat this procedure to verify your changes. If you find that sometimes you are a frame or two early and sometimes a frame or two late, select the midpoint for the offset.

See *Accessing and Changing Offset Parameters* at the end of this chapter.

Record VCR (VCRR) IN and OUT OFFSETS

After the Out Offsets for the Play VCRs are adjusted, determine whether the In and Out Offsets for the Record VCR need to be adjusted. The IN OFFSET determines when the Record command is sent. The OUT OFFSET determines when the Record Pause command is sent.

To determine if the Record VCR In and Out Offsets need to be adjusted:

1. Insert a blank tape in the Record VCR and rewind the tape.

If PROTO=422 and TCSRC=INT, follow the instructions in your VCR manual to prestripe your tape, then position the tape approximately one minute from the start.

2. Use the up/down arrow keys to display the first of the three events you created in the *Preparation* section.

3. If the record VCR uses IR control, put the VCR in Record Pause.
4. Press [SHIFT]+[AUTO REC] to record the three scenes.
5. After the three scenes are recorded, press [R] to select the record VCR. (If the record VCR uses IR, you will have to control it manually.)
6. Use the jog/shuttle to locate the start of the second scene.

If the scene started earlier than the IN point, the value for VCRR's In Offset is too large. If it started later than the IN point, the offset is too small. Use the same approach as you used for the Play VCRs OUT OFFSET to determine the amount of error and the amount of change to the current offset value. Change the IN OFFSET and continue with Step 7.

See *Accessing and Changing Offset Parameters* at the end of this chapter.

7. Use the jog/shuttle to locate the end of the second scene.

If the scene ended earlier than the OUT point, the value for VCRR's OUT OFFSET is too large. If it ended later than the OUT point, the offset is too small. Use the same approach as you used for the Play VCRs OUT OFFSET to determine the amount of error and the amount of change to the current offset value. Change the OUT OFFSET.

8. Repeat these steps to verify your changes.

If you do not have an MX-1 or a mixer/switcher, this concludes the fine-tuning procedure. If you have a Mixer or Switcher, continue with the next section.

Play VCRs IN OFFSET

The Play VCR IN OFFSET is used only during A/B Rolls and is used to determine when the play command needs to be sent to the "B" Roll VCR in order to start the transition at the correct time. If you are not using a mixer, you do not need to adjust this parameter.

To determine if the Play VCR IN OFFSET needs to be adjusted:

1. You need two source VCRs, and two more events in the EDL.

The first new event is an MX1 or MIXER Event, and it should be created immediately following the scene 002 event. Select a transition—like MX-1 transition 6—that will allow you to judge the midpoint of the transition. Select the speed or duration you use most

often for your productions.

The second new event is a Scene Event (A, B, C or D), and it should immediately follow the MX-1 or MIXER event. The new event should be from a different play VCR than scene 002. The EDL should look similar to one of the EDLs below.

001 DUR 00:00:10.00 SRC COL=0	001 IN 00:05:22.04 A OUT 00:05:35.20
002▼ IN 00:07:05.12 A OUT 00:07:17.00	002▼ IN 00:07:05.12 A OUT 00:07:17.00
002/004 FX=006 DI=> MX1 SP=5 BG=0 BC=_	002/004 TRANS DUR MIXER 00:00:03.00
004▲ IN 00:22:22.01 B OUT 00:22:45.10	004▲ IN 00:22:22.01 B OUT 00:22:45.10
003 DUR 00:00:10.00 SRC COL=0	003 IN 00:05:22.04 A OUT 00:05:35.20

2. Use the up arrow to move to the first event in the EDL.
3. If the Record VCR uses IR control, put the VCR into Record Pause.
4. Press [SHIFT]+[AUTO-REC] to record the scenes.
5. After the scenes are recorded, press [R] to select the record VCR. (If the Record VCR uses IR, you will have to control that VCR manually.)
6. Check the resulting video on the Record VCR for the midpoint of the transition from A to B. If the "B" scene started early, the IN OFFSET for the B-Roll VCR is too large; if it started late, the offset is too small. (Note: The "B" VCR in this case is the second source in the A/B Roll and not necessarily the VCR attached to the "B" port.)
7. Use the same approach as you used for the Play VCRs OUT OFFSET to determine the amount of error and the amount of change to the current offset value. Change the IN OFFSET value.
8. Repeat steps 2 through 7 to verify your changes.

9. Repeat the above procedure for each play VCR that may be the "B" source in an A/B Roll.

Accessing and Changing Offset Parameters:

1. Press [SETUP] to display Setup Menu 1.

```
LCD CONFIG NEWVCR
IMPORT EXPORT CMX ▾
```

2. Move the cursor to CONFIG and press [OK] to display the Configuration Menu.

```
VCRA VCRB VCRC VCRD
VCRR GPI-M GPI-T
```

3. Move the cursor to the VCR port (VCRA, VCRB, ... ,VCRR) whose offsets you are ready to adjust and press [OK]. The first parameter screen for that port displays.

```
PROTO=PANA
VCR=001 PREROLL=05 ▾
```

4. Press the down arrow key three or four times until the IN/OUT OFFSET screen is displayed.

```
IN OFFSET=-0048 ▲
OUT OFFSET=-0048 ▾
```

5. To change an offset value–

- Move the cursor to the ± Sign field if that value needs to change and press [CHG].
- Move the cursor to the Offset Amount field if that value needs to change, press [CHG] to activate the numeric keys, then enter the new value for the offset.
- Press [SETUP] to save your changes and return to the Configuration Menu. Press [SETUP] two more times to return to the EDL.

Chapter 8 ◦ Importing and Exporting

If you have access to a personal computer (PC) and a communications software program, you can use Edit Suite's IMPORT, EXPORT, and CMX functions to—

- export the EDL and Configuration Parameters to a PC
- import a previously exported EDL and parameters to Edit Suite
- export the EDL, in CMX format, to a PC.

The EXPORT and IMPORT functions are for storage purposes only. You cannot view the file in a readable format or edit the EDL data.

The CMX export displays in a readable format, but the format is different from the EDL format. Although this output was designed to make the EDL available to an on-line suite (PC-based editing), it is used most often to view the EDL information.

Cable

To connect Edit Suite to a PC, you need a serial communications cable. These cables are available at most computer supply stores. For a Macintosh, the cable is an 8-pin DIN to DB-9. A Videonics 232/422 cable (CBLA-0042-01) may be used.

For most other computers, the cable is a DB-9 to DB-9 or DB-25 to DB-9 serial communications cable.

Before connecting the cable, remove power from the computer and Edit Suite.



Macintosh Modem Port (8-pin DIN) to Edit Suite's Computer (RS-232C) DB-9 Port



PC Serial Comm Port (DB-9 or DB-25) to Edit Suite's Computer (RS-232C) DB-9 Port

Communication Programs and Settings

Edit Suite can communicate with most communication software programs that support XOn/XOff Flow Control. The table on the following page identifies three communication programs we have tested with Edit Suite, and the settings for each. Adapt these settings to your software package.

Communication Programs and Settings			
Computer	Macintosh	PC DOS	PC Windows
Communications Program	MicroPhone II	ProComm	Terminal
Communications Menu			
Method Driver	Microphone Std. Standard	Press Alt-P and select table 12.	
Baud Rate	19,200	19,200	19,200
Data Bits	8	8	8
Parity	None	None	None
Stop Bits	1	1	1
Flow Control	XOn-XOff		XOn-XOff
Parity Check			(blank)
Carrier Detect			(blank)
Text Transfer			
End Outgoing Lines with:	CR		
Save Text As:	Teach Text		
Wait for Echo	None		
Flow Control			Standard
ASCII Transfer			
Echo Local		Press Alt-S, select menu 6.	
Expand Blank Lines		Yes	
Pace Characters		Yes	
Character Pacing		0	
Line Pacing		23	
Down Loading		11	
CR		None	
LF		None	
Up Loading			
CR		None	
LF		None	
Terminal Emulation			DEC VT-100 or DEC VT-52
Terminal Preferences			
Line Wrap			X
Local Echo			X
Sound			X
CR->CR/LF			
Inbound			(blank)
Outbound			(blank)
Transfer/Send Menu			
Protocol	ASCII/Text		

Ensure that all settings are correct before you begin communicating with Edit Suite. Test by running Edit Suite's Export function without saving the data that is sent. You should see 255 lines of 32 characters per line scroll down your PC display. If not, either some of the above values are not set properly or your modem/communications port is not configured for computer-to-computer communications. Consult your PC or communication manuals for more information.

Export

The Export function is used to save all EDL and Configuration Data to a file on a personal computer. The file cannot be edited at the PC, and it is not in a readable format. The file can be sent back to Edit Suite via the Import function.

To do an export, complete the following steps.

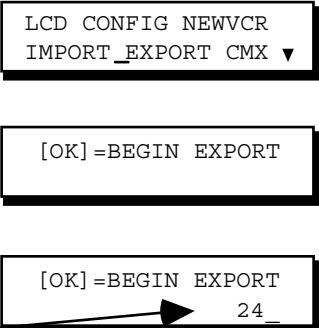
#	Step	Macintosh MicroPhone II	PC DOS ProComm	PC Windows Terminal
1.	At the PC, start the communications program.			
2.	At the PC, create a file to save the Edit Suite data.	Select <i>Open New Capture File</i> in the File Menu. Select a directory and file name. Click <i>SAVE</i> .	Press [Page Down] to display the Download Protocol menu. Select Protocol 7 (ASCII). Assign a file name and press return.	Select <i>Receive Text File...</i> in the Transfers Menu. Select a directory and file name. Click <i>OK</i> .
3.	At Edit Suite: a. Press [SETUP] to display Setup Menu 1 and move the cursor to Export. b. Press [OK] to display the Export screen. c. Press [OK] to start the export — or — press [SETUP] to cancel the export.			 <p>While the export is in progress, line numbers between 00 and FF sequence on the display.</p>
4.	After the Edit Suite counter stops counting and the Setup Menu redisplay, at the PC, stop the file capture.	Select <i>Turn Capture Off</i> in the File Menu.	(No action required.)	Select <i>Stop</i> in the Transfers Menu.



Import

The import function is used to restore a previously exported Edit Suite file.

IMPORTANT: If an import is done, all EDL and configuration data currently stored in Edit Suite will be replaced by the imported data. All work-in-progress will be lost.

Before attempting an import, ensure that all communication settings are correct. If the connections are not correct and the import fails, Edit Suite displays an NVRAM INIT message indicating that all EDL and configuration data has been deleted and the unit has been reset to factory conditions.

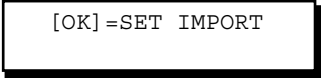
To do an import, complete the following steps.

#	Step	Macintosh MicroPhone II	PC DOS ProComm	PC Windows Terminal
1.	At the PC, start the communications program.			
2.	At the PC, locate and select the previously exported EDL file that you want to send to Edit Suite ... BUT DO NOT START SENDING THE FILE YET.	In the Transfer menu, select <i>Send ...</i> , and set the Protocol to ASCII/Text. Locate and select the file to be sent, but do not click [SEND] .	Press [Page Up] to display the Upload Protocol menu. Select Protocol 7 (ASCII). Type the filename to be sent, but do not press Return.	Select SendText File... in the Transfers Menu. Locate and select the file to be sent, but do not click [OK].
3.	At Edit Suite: a. Press [SETUP] to display Setup Menu 1 and move the cursor to Import. b. Press [OK] to display the Import screen. c. Press [OK] to prepare Edit Suite for the import and to start a 10-second time-out counter. — or — press [SETUP] to cancel the import.			   <p>While the 10-second time out is in progress, the wait indicator displays. If Step 4 is done before the 10 seconds elapse, line numbers between 00 and FE sequence on the display, after which Setup Menu 2 displays.</p> <p>If 10 seconds elapse before Step 4 is done, the Import is terminated and Setup Menu 2 redisplay.</p>
4.	At the PC, and within 10 seconds of completing Step 3, start sending the file.	Click [SEND].	Press [Return].	Click [OK].

CMX



The CMX function exports the EDL data, in CMX format, to a PC. This function is used most often to view the entire EDL in a single listing.

Before using the CMX function, ensure that—

- if there are MX1 Events in the EDL, the GPI-M configuration parameter is set to MX-1; or if there are MIXER Events, the GPI-M configuration parameter is set to MIXER
- if there are INS or SPLT events in the EDL, the INS and SPLT parameters for VCRR are set to 1.

If these settings are not correct, an error message will display during the export, or the event will be excluded from the CMX report.

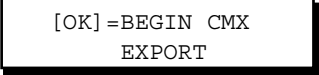
To do a CMX Export, complete the following steps.

#	Step	Macintosh MicroPhone II	PC DOS ProComm	PC Windows Terminal
1.	At the PC, start the communications program.			
2.	Do this step if you want to save the CMX data to a file. If you just want to view the CMX listing, omit this step.	Select <i>Open New Capture File</i> in the File Menu. Select a directory and file name. Click <i>SAVE</i> .	Press [Page Down] to display the Download Protocol menu. Select Protocol 7 (ASCII). Assign a file name and press return.	Select <i>Receive Text File...</i> in the Transfers Menu. Select a directory and file name. Click <i>OK</i> .
3.	At Edit Suite: a. Press [SETUP] to display Setup Menu 1 and move the cursor to CMX. b. Press [OK] to display the CMX screen. c. Press [OK] to start the CMX export — or — press [SETUP] to cancel the export.			  
4.	If you saved the data to a file, stop the file capture.	Select <i>Turn Capture Off</i> in the File Menu.	(No action required.)	Select <i>Stop</i> in the Transfers Menu.

The following is a sample CMX listing.

CMX EVENT#	VCR (001=A, 002=B, 003=C, 004=D) or Color (BL=Black, AX=Other Color)	Insert Type (AA=Audio, V=Video)	Transition Type (C=Cut, D=Dissolve, Wnnn=Wipe+Wipe#)	Transition Duration (Frames: Max=255)				
TITLE: EDIT SUITE EXPORT OF CMX 3400A EDL								
FCM:	NON	DROP	FRAME					
001	BL		C		00:00:00:00	00:00:10:00	01:00:00:00	01:00:10:00
002	001		C		00:05:00:00	00:05:15:00	01:00:10:00	01:00:25:00
003	002		C		00:03:10:00	00:03:25:00	01:00:25:00	01:00:40:00
004	001		C		00:05:00:00	00:05:15:00	01:00:40:00	01:00:55:00
004	002		W001	255	00:03:10:00	00:03:25:00	01:00:55:00	01:01:10:00
005	001		C		00:05:00:00	00:05:15:00	01:01:10:00	01:01:25:00
006	001		C		00:06:00:00	00:06:15:00	01:01:25:00	01:01:40:00
007	002		C		00:03:30:00	00:04:00:00	01:01:40:00	01:02:10:00
GPI	GPI-T		PULSE		001	RI	+00:00:15:00	
008	002	AA/V	C		00:21:20:00	00:21:40:00	01:15:00:00	01:15:20:00
EDIT SUITE STOP TITLE								
GPI (always Relative In)								

CMX Notes:

1. The CMX event numbers are sequential beginning with 001 – regardless of the EDL event numbers.
2. Sources are shown as 001 - 004 in CMX and A - D in Edit Suite.
3. An A/B Roll is shown as two lines in the CMX report, and both lines use the same event number (whereas Edit Suite uses two numbers).
4. There are three types of transitions in the CMX output: Dissolves, Cuts, and Wipes. Wipes are followed by a three-digit number. This is not the MX-1 transition number.
5. If an AXA Roll is in the EDL, the transition is ignored in CMX.
6. If an A/B/A or A/B/C Roll is in the EDL, the "B" scene will be divided into two events in the CMX export.
7. All GPI events are converted to Relative In for the CMX export.
8. If a Source event is the "A" source in an A/B Roll, its duration will display as 0.
9. Edit Suite does not store record deck times (except for insert events). For the CMX report, the record times begin at 01:00:00:00 and show the running time for the production.

The EDL:

The following are the EDL events that generated the CMX output on the preceding page.

001	DUR_00:00:10.00
SRC	COL=0

002	IN 00:05:00.00
A	OUT 00:05:15.00

003	IN 00:03:10.00
B	OUT 00:03:25.00

004▼	IN 00:05:00.00
A	OUT 00:05:15.00

004/005	FX=025 DI=>
MX1	SP=3 BG=0 BC=5

005▲	IN 00:03:10.00
B	OUT 00:03:25.00

006	IN 00:05:00.00
A	OUT 00:05:15.00

007	IN 00:06:00.00
A	OUT 00:06:15.00

008▼	IN 00:03:30.00
B	OUT 00:04:00.00

008▲	FIXED
GPI-T	00:03:45.00

009▼	IN 00:21:20.00
B	OUT 00:21:40.00

009▲	IN 01:15:00.00
INS _A _V	OUT 01:15:20.00

	TOTAL RT
STOP	00:02:30.00

Chapter 9 • Setup and Configuration Menus

This chapter describes the choices in the Setup and Configuration Menus.

Setup Menus

The Setup Menus access functions that are used to—

- change the LCD viewing angle
- turn on or off the beeper, error message text and the demo
- import and export the EDL to a personal computer
- add new VCR table definitions provided by Videonics.

The Setup Menus are also used to access the Configuration Menu. This menu is used to configure Edit Suite's VCR and GPI ports so they can be used with your VCRs, camcorders, mixer and titler.

To display Setup Menu 1, press [SETUP].



Setup Menu 1 Setup Menu 2

To move between Setup Menu 1 and 2, press the [up/down arrow] keys.

To exit the Setup menus, with either Setup Menu 1 or 2 displayed, press [SETUP]. You are returned to the EDL event you were viewing before [SETUP] was pressed. If there are no events in the EDL, the NEW Menu displays. See Chapter 5 for a description of the NEW Menu.

To exit Setup from the Configuration Menu, press [SETUP] to return to Setup Menu 1, then press [SETUP] again to return to the EDL.

To select a Setup function or to display the Configuration Menu, use the [left/right arrow] keys to

move the cursor to the choice you want, then press [OK].

Setup Functions

The following table briefly describes each of the EDL functions.

LCD	<p>Changes the viewing angle for the LCD. To adjust the angle, change the LCD Contrast value from its default of 1 to a new value.</p> <p>To change the value, first move the cursor to LCD and press [OK] to display the LCD Contrast screen. Next, press [CHG] and turn the jog until the setting you want is displayed. Press [OK] to save the new value and return the Setup Menu 1.</p>
CONFIG	<p>Selects the Configuration menu and parameters. The configuration parameters identify the devices attached to Edit Suite, and provide instructions for communicating with each device. The configuration parameters are described in the next sections.</p>
NEWVCR	<p>Adds new VCR tables to Edit Suite. From time to time, Videonics may create tables to support new VCRs or VCR protocols. These tables can be added to Edit Suite by typing in strings of numbers provided by Videonics or by sending a file to Edit Suite from a PC. Instructions for using the function will be provided with the table data.</p> <p>If you inadvertently access this function, press [CHG] and wait for the 10-second timeout to be returned to Setup Menu 1, or press the POWER button twice to recycle power to Edit Suite.</p>
IMPORT	<p>Imports to Edit Suite a previously exported EDL and the associated VCR configuration data. This replaces all current EDL and configuration information with the information from the imported file. See Chapter 8 for details.</p>
EXPORT	<p>Exports the EDL and deck configuration information to a personal computer. See Chapter 8 for details.</p>
CMX	<p>Exports the EDL data, in CMX format, to a computer. See Chapter 8 for details.</p>

EDL	Deletes all events in the Edit Decision List. After the events are deleted and the Setup menus are exited, the New Menu displays.
BEEPER	Turns on (1) or off (0) the <i>beep</i> function for confirmation and/or error conditions.
MSGS	Turns on (1) or off (0) the wording that accompanies error and advisory messages.
DEMO	Turns on (1) or off (0) the demo (scrolling feature list) that displays when the power supply is connected to Edit Suite or the POWER button is pressed.

VCR Configuration Menu and Parameters

The VCR Configuration Parameters are used to configure Edit Suite's VCR Control Ports (A, B, C, D and REC) so that the correct commands are sent to each of your VCRs and camcorders.

To display the Configuration Menu, from Setup Menu 1, move the cursor to CONFIG and press [OK]. To return to Setup Menu 1 from the Configuration Menu, press [SETUP].



Setup Menu 1 Configuration Menu

To access the Configuration Parameters for a VCR port, in the Configuration Menu, move the cursor to the VCR port you want to configure and press [OK]. The first Configuration Parameter screen for that VCR port displays.

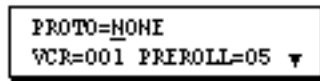

To return to the Configuration Menu from the Configuration Parameters, press [SETUP]. When you do this, Edit Suite saves your changes and builds a Control Table for the VCR port. Depending on which parameters were changed, it may take several seconds for Edit Suite to build the VCR Control Table. During this time, a spinning "wait" indicator displays in the bottom row of the LCD near the right side.

Configuration Parameters

The Configuration Parameters are divided into three groups: VCR Definition, VCR Tuning, and VCR Search. There are a few more parameters for the record VCR than for the Play VCRs.

VCR Definition Parameters

Play VCRs/Camcorders Record VCR

PROTO= <u>NONE</u> VCR=001 PREROLL=05 ▼	PROTO= <u>NONE</u> VCR=001 PREROLL=05 ▼
--	--

TCSRC= <u>INT</u> TC= <u>NONE</u> ▲ ▼	TCSRC= <u>INT</u> TC= <u>NONE</u> ▲ INS=0 SPLT=0 ▼
--	---

VCR Tuning Parameters

Play VCRs/Camcorders Record VCR

IN OFFSET= <u>-0048</u> ▲ OUT OFFSET= <u>-0048</u> ▼	IN OFFSET= <u>-0424</u> ▲ OUT OFFSET= <u>-0016</u> ▼
---	---

InzIN InzOUT SPLT ▲ <u>+0000</u> +0000 +0000 ▼

VCR Search (Advanced) Parameters

Play VCRs/Camcorders Record VCR

<u>ADVPARAMS</u> ▲	<u>ADVPARAMS</u> ▲
--------------------	--------------------

PLY= <u>00</u> :15 REW=00:30 FFD=02:00 ▼	PLY= <u>00</u> :15 REW=00:30 FFD=02:00 ▼
---	---

```
STABLE=45 RETRY=03 ▲  
TOLERANCE=03
```

```
STABLE=45 RETRY=03 ▲  
TOLERANCE=03
```

- To move between the parameter screens, use the [up/down arrow] keys.
- To access the VCR Search parameters, from the ADVPARAMS screen, press [OK].
- To return to the ADVPARAMS screen from the search parameters, press [SETUP].
- To return to the Configuration Menu from the Definition or Tuning Parameters, press [SETUP].
- To change the PROTO (protocol), TCSRC (time code source), TC (time code type) values, INS (insert) or SPLT (split insert) choices, press [CHG] to cycle through the list of choices. If RS-232 (232) protocol is selected, choice lists for Baud Rate and Character Format also display. If the Record VCR uses IR protocol, a choice list for the command used to change from Record Pause to Record displays.
- To change any other parameter value, move the cursor to the field, press [CHG] to activate the numeric keys, then type a new value or use the jog/shuttle to change the existing value and press [OK].

VCR Definition Parameters

The VCR Definition Parameters specify the type of protocol used by the VCR or camcorder, the VCR table number used to control the VCR, the type of time code used, if any, and whether the time code is delivered over the Edit Control Cable or an Audio/Video cable. The Definition Parameters also specify the preroll duration and, for the Record VCR only, whether the VCR is capable of doing Insert Editing and Split Insert Editing.

Play VCRs/Camcorders Record VCR

```
PROTO=NONE  
VCR=001 PREROLL=05 ▼
```

```
PROTO=NONE  
VCR=001 PREROLL=05 ▼
```

```
TCSRC=INT TC=NONE ▲  
▼
```

```
TCSRC=INT TC=NONE ▲  
INS=0 SPLT=0 ▼
```

• **PROTO** (Protocol) is the type of control protocol used by your VCR or camcorder. Check your VCR/camcorder manual to determine the correct choice. Choices are:

LANC Sony Control-L

PANA Panasonic Control-M

232 RS-232 (Baud Rate and Character Format choices display)

422 RS-422

IR Infrared; Record VCR only. (CMD choices display)

NONE Not used, or a noncontrollable video source is attached to the corresponding port on a mixer/switcher.

- **VCR** is the VCR Table number to use. See Appendix A for a full list of choices.
- **PREROLL** is the number of seconds the VCR/camcorder should preroll before a scene is played. Typically this value is 05—five seconds. It may need to be increased to 12 for play VCRs/camcorders if insert editing is used and a VCR with PANA protocol is the Record VCR.

For Record VCRs, only VCRs that require a preroll are prerolled. For the most part, this is VCRs with RS-422 protocol. Leave the value at 05.

- **TCSRC** (Time Code Source) and **TC** (Time Code Type). TCSRC specifies whether time code is sent through the Edit Control Cable (INT) or through an audio/video cable attached to the Time Code IN port (EXT). TC specifies the type of time code being used.
 - If Time Code is not used, select TCSRC=INT and TC=NONE.
 - For most RS-232 and RS-422 VCRs, select TCSRC=INT and TC=NONE, VITC, LTC or RCTC, depending on which time codes are available and selected on the VCR.
 - For LANC VCRs and camcorders with RCTC, select TCSRC=INT and TC=RCTC.
 - For LANC and PANA play VCRs with VITC or LTC striped on the play tape,

select TCSRC=EXT and TC=LTC or VITC.

- For LANC and PANA Record VCRs, select TCSRC=INT and TC=NONE.

If you select EXT, you must attach an audio (LTC) or video (VITC) cable from the VCR to the appropriate Time Code IN port on Edit Suite.

See Appendix A for more information about the TCSRC and TC choices.

• **INS** (insert) and **SPLT** (split insert) are for the record VCR only, and specify whether the VCR is capable of doing insert editing and split insert editing. 0=no, 1=yes.

Refer to the instruction manual for your record VCR to determine if it has these capabilities. Refer to the Insert Event and the Split Insert Event sections of Chapter 5 for a description of these features.

VCR Tuning Parameters

The Tuning Parameters are used to improve the accuracy of your edits. They adjust the timing Edit Suite uses when it sends play, pause, record, and record pause commands to the VCRs during normal recording operations. They also adjust the recorder timing when insert or split insert editing is done.

Play VCRs/Camcorders Record VCR

IN OFFSET=-0048 ▲	IN OFFSET=-0424 ▲
OUT OFFSET=-0048 ▼	OUT OFFSET=-0016 ▼

InsIN InsOUT SPLT ▲
+0000 +0000 +0000 ▼

Procedures for adjusting the IN OFFSET and OUT OFFSET parameters are described in Chapter 7, *Fine Tuning*. The InsIN, InsOUT and SPLT parameters adjust the timing for Inserts and Split Inserts. Refer to the Insert Event and the Split Insert Event sections of Chapter 5 for a description of these parameters.

VCR Search (Advanced) Parameters

The Search Parameters control how Edit Suite searches for scenes when the GO TO function is used and when an auto-record, preview, or review is done. These parameters tell Edit Suite when it should switch

from Fast Forward to Cue and from Cue to Play. They also tell it how long to wait after issuing a Play command before reading the time code, and how far to Rewind when the videotape is positioned close to or beyond the search point.

To access the search parameters, display the ADVPARAMS screen and press [OK]. To return to the ADVPARAMS screen from either of the Search Parameter screens, press [SETUP].

Play VCRs/Camcorders Record VCR



The PLY (play), REW (rewind), FFD (fast forward) and STABLE parameters are used when Edit Suite controls the search process.

Most RS-232 and RS-422 VCRs control their own searches, so these parameters are ignored—unless RS-232 table 006, 021 or 024 is used or RS-422 table 021 is used. These tables are used if external LTC or VITC is used with an RS-232 or RS-422 VCR, in which case Edit Suite needs to control the search process.

The default values for the search parameters will work for most VCRs and camcorders; however, you may need to adjust the parameters if Edit Suite misses or is late starting a scene during a preview or an auto-record.

When you adjust the parameters, observe the following precautions:

- PLY (play) should never be less than 10; the recommended minimum is 12.
- PLY must be less than or equal to REW (rewind).
- PLY and REW must be less than FFD (Fast Forward).
- Increasing STABLE also requires an increase in PLY. For every increase in STABLE by

10, increase PLY by 1.

- If External VITC or LTC is NOT being used, STABLE may be decreased from its default value of 45 to a value of 15. If STABLE is decreased to 15, PLY may be decreased to 12.
- STABLE should not be decreased to a value less than 15.
- With REW set to 30, the earliest scene you can mark on a tape is approximately 45 seconds to one minute from the start of the tape. If REW is decreased, scenes may start earlier on the tape by a corresponding amount.
- REW may be set as low as PLY (12-15); however, decreasing REW may prevent Edit Suite from rewinding far enough to reach the search point—in which case the scene will be missed.

At the start of a search, if external LTC or VITC is used, Edit Suite issues a Play command, waits for the stable period (approximately 1/10th of a second times the STABLE value), and then reads the VITC or LTC. This allows enough time for the VCR to change to Play speed from Stop, Fast Forward, etc., and to be delivering readable time code data. Edit Suite uses this new reading of the time code to determine the relationship between the time code and the real time counter for the VCR.

Next, Edit Suite determines which way it needs to move the VCR transport. It does this by comparing the current time with the search point. For a GO TO, the search point is the IN or OUT point of the current event plus or minus the OUT OFFSET amount for the VCR. For a preview or an auto-record, the search point is the IN time for the event minus the PREROLL time, plus or minus the OUT OFFSET amount for the VCR.

If the tape is more than two minutes (the FFD value) earlier than the search point, Edit Suite issues a Fast Forward command to the VCR. When it reaches the FFD value, a Cue command is issued. The VCR will remain in Cue until it is approximately 15 seconds (the PLY value) from the search point. When the PLY value is reached, Edit Suite issues a Play command, waits for the stable period, reads the time code and real time counter values, and makes any final adjustments necessary to reach the target.

If the tape is between the FFD and the REW parameter values when the search is started, the search begins with a Cue instead of a fast forward.

If the tape is closer to the target than the REW value or if it is beyond the target, Edit Suite issues a Rewind command. The VCR stays in Rewind until the tape is at least the REW parameter value away from the target. A Cue is then issued, followed by a Play when the PLY value is reached.

RETRY and TOLERANCE should not be modified. Leave them set to 03.

This table summarizes the initial settings to use for VCRs and Camcorders with LANC, PANA, RS-232 and RS-422 protocol. Refer to Appendix A for more information about the VCR Definition Parameters and the VCR tables to use.

VCR Configuration Parameters

Parameter Name	Initial Values for Each Protocol Type (Except IR & None)			
PROTO (protocol)	LANC*	PANA	232	422
VCR (VCR table number)	001 - VCRs 002 - Camcorders 007 - CCD-V5000 012 - Canon	001	001 - Sony 003 - Panasonic 004 - JVC	001
PREROLL	05	05	05	05
TCSRC (Time Code Source)	INT (for real time counter or RCTC) EXT (for VITC or LTC)	INT (for real time counter) EXT (for VITC or LTC)	INT	INT
TC (Time Code Type) [Use NONE if Real Time Counter is to be used.]	NONE RCTC VITC LTC	NONE VITC LTC	NONE RCTC VITC LTC	NONE VITC LTC
INS (VCRR Only)	Is record deck capable of Insert Edits? 0 = No, 1 = Yes.			
SPLT (VCRR Only)	Is record deck capable of Split Insert Edits? 0 = No, 1 = Yes.			

IN OFFSET	-0048	-0048	-0048	-0048
- Play Decks	-0424	-0424	-0424	-0424
- Record Deck				
OUT OFFSET	-0048	-0048	-0048	-0048
- Play Decks	-0016	-0016	-0016	-0016
- Record Deck				
InsIN (VCRR Only)	+0000	-1340 for PAL -1608 for NTSC	+0000	+0000
InsOUT (VCRR Only)	+0000	+0000	+0000	+0000
SPLT (VCRR Only)	+0000	+0000	+0000	+0000
ADVPARAMS	Press [OK] to access the remaining parameters. Press [SETUP] to return to the ADVPARAMS tile.			
PLY (play)	00:15	00:15	00:15	00:15
REW(rewind)	00:30	00:30	00:30	00:30
FFD (fast forward)	02:00	02:00	02:00	02:00
STABLE	45	45	45	45
RETRY	03	03	03	03
TOLERANCE	03	03	03	03

Note: For LANC VCRs with RCTC, if the VCR/camcorder counter goes blank or skips values when it is in Fast Forward or Rewind, use VCR tables 121-126 instead of the tables listed above. See Appendix A for more information.

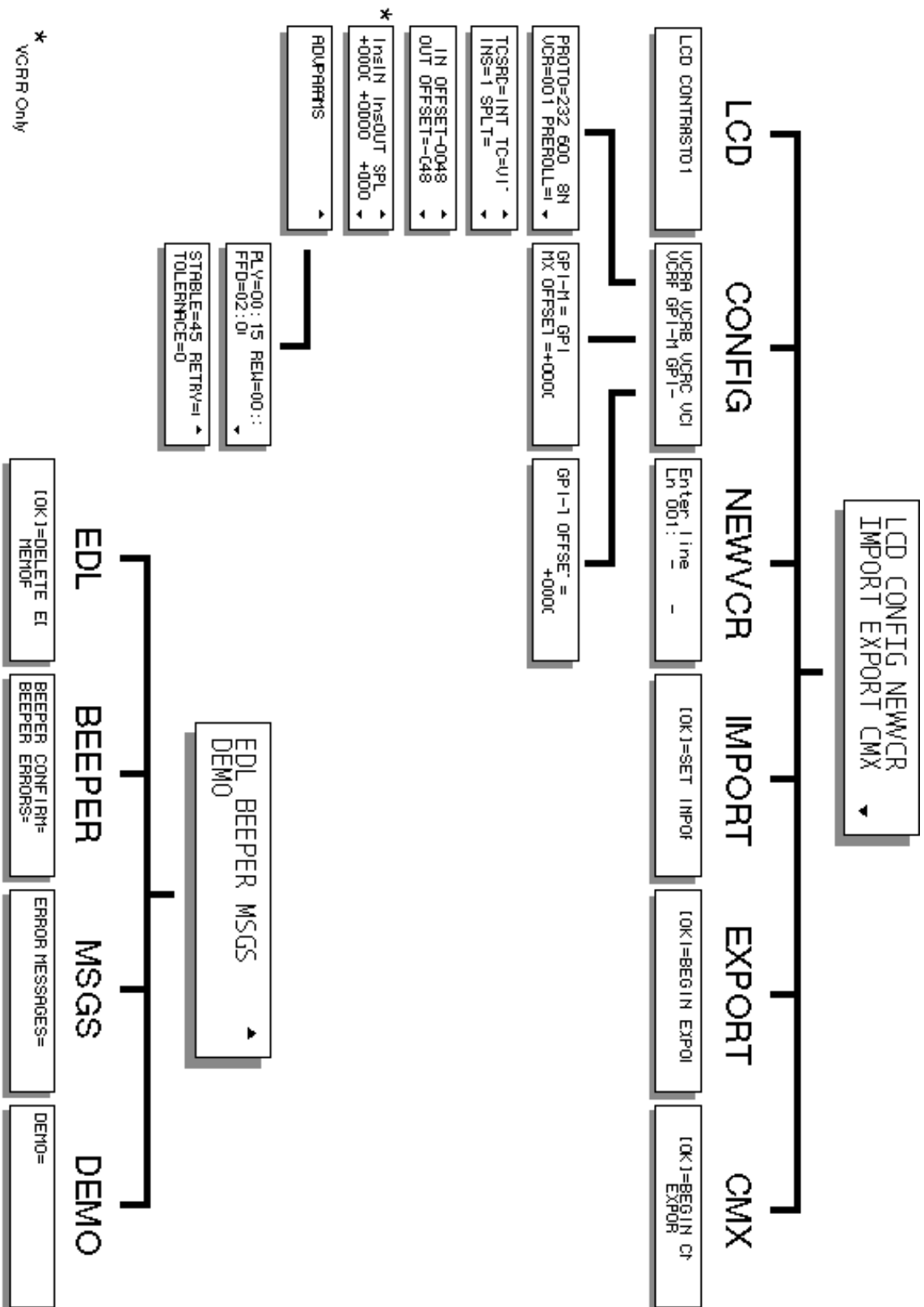

GPI-M and GPI-T Configuration Parameters

The GPI-M choice in the Configuration Menu is used to specify the type of GPI (general purpose interface) device that will be attached to Edit Suite's GPI-M port—a Videonics MX-1, a third-party mixer or switcher, or another type of GPI-device. For the latter choices, it is also used to specify the offset

amount to use so that Edit Suite sends the GPI trigger at the correct time.

The GPI-T choice is used only for specifying the offset value for the trigger pulses. See GPI Events in Chapter 5 for more information. The MX-1 and third-party mixers/switchers cannot be used with the GPI-T port.

To display the Configuration Menu, from Setup Menu 1, move the cursor to CONFIG and press [OK]. To return to Setup Menu 1 from the Configuration Menu, press [SETUP].



Setup Menu 1 Configuration Menu

To access the GPI-M or GPI-T parameters, move the cursor to GPI-M or GPI-T in the Configuration Menu and press [OK].

GPI-M Choices GPI-T

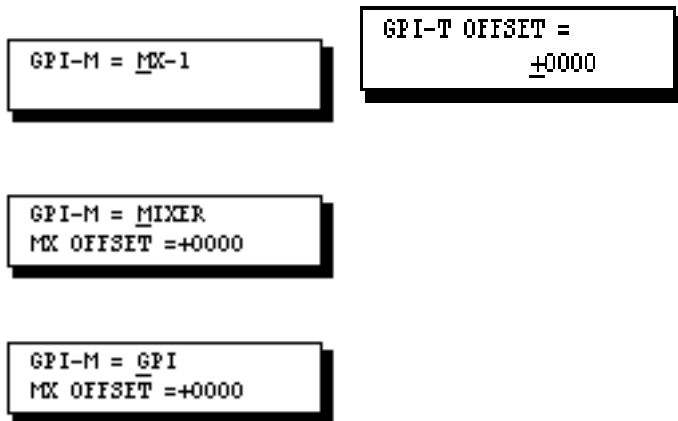

The GPI-M Choices above show each of the choices for the GPI-M port. To cycle between the choices, with the cursor in the GPI-M field, press [CHG]. Select MX-1 if a Videonics MX-1 is attached to the GPI-M port; select MIXER if a third-party mixer or switcher is attached; select GPI if a GPI-device other than a mixer or switcher is used, or if no device is attached to the port.

To change the sign (+ or -) for either of the GPI-M or GPI-T offset values, move the cursor to the sign field and press [CHG].

To change the Offset values for GPI-M or GPI-T, move the cursor to the offset value field, press [CHG] to activate the numeric keys, enter the offset amount (or turn the jog/shuttle to change the current value),

and press [OK]. See MIXER Events or GPI Events in Chapter 5 to determine the amount of offset.

To return to the Configuration Menu from either GPI parameter screen, press [SETUP].

Chapter 10 • Error Messages and Troubleshooting

This chapter provides two tables to help you solve problems that may occur while using Edit Suite. These are the Error Messages Table and the Troubleshooting Table.

The Error Messages Table lists each Error Message that displays in Edit Suite, describes the cause of the error, and provides actions for you to take to fix the error or prevent it from occurring again. The Troubleshooting Table lists problem symptoms that you may encounter, and provides the actions to take to isolate, prevent, or work around the cause of the problem.

Error Messages

If Edit Suite detects an error or advisory condition, it displays an error message similar to the following.

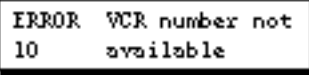

```
ERROR VCR number not
10 available
```

To clear an error message, press [OK]. To redisplay the most recent error message, press [SHIFT]+[OK].

Error Message Table

#	Message, Meaning, and Action
01	<p>Out pt before in pt</p> <p>During a preview or auto-record, a scene event whose OUT time is the same as or earlier than its IN time was detected.</p> <p>Change the scene's IN and/or OUT time and rerun the preview or auto-record. To locate the scene on the videotape, display the event in the LCD, then press [GO TO]+[IN] or [GO TO]+[OUT].</p>

05 No response from VCR

Edit Suite attempted to communicate with a VCR but did not receive or could not recognize the response from the VCR.

Verify that the control cable between Edit Suite and the VCR is connected, that a videotape is loaded, and that the VCR is turned on. If the VCR has a Master/Slave switch, select Slave. If it has a Local/Remote switch, select Remote.

Of special note are VCRs like the Sony EV-S7000 and EV-S9000P. Both of these VCRs have a menu selection for Master/Slave that defaults to Master whenever power is removed from then reapplied to the VCR. Make sure you reselect Slave.

Verify that the correct protocol is selected in CONFIG/VCR_/PROTO. If the VCR uses RS-232 or RS-422 protocol, press [SHIFT] +[STOP] to reinitialize communication with the VCR.

06 Split delay out of range

The amount of delay in a SPLT event is greater than or equal to the length of the insert.

Decrease the amount of delay in the SPLT event.

09 Tape address not found

Edit Suite searched for a time code or counter address but was unable to locate the address.

The scene Edit Suite is looking for may be too close to the start of the tape. Scenes should not start earlier than approximately one minute from the start of a fully rewound tape.

Reattempt the preview, auto-record or GO TO. If the error occurs again, verify that the correct videotape is loaded.

If time code is not being used, rewind the tape, reset the counter, and try again. If RCTC is used, verify that the VCR/camcorder is set to send time code and that the tape is striped with RCTC.

If the problem persists, increase the PLY (play) Advanced Parameter by five (5) seconds, but be sure that the REW (rewind) parameter value is equal to or greater than PLY and that both are less than the FFD (fast forward) parameter.

Error 9 also displays if a search is in progress but is terminated early by pressing a Transport key or turning the Jog/Shuttle.

10 VCR number not available

During VCR Configuration, a VCR number that is not defined in Edit Suite was entered.

The VCR table number will be changed automatically to table 001. If table 001 is not the table you want to use, return to the VCR field and enter one of the table numbers from Appendix A.

11 VCR table corrupt

The selected VCR table number is not usable, Edit Suite's memory has become corrupt, or there is a problem with the LCD.

Unplug then reconnect power to Edit Suite to reset its memory. If the error persists, retype the VCR number for each VCR. If this does not fix the problem, select a different VCR table number from Appendix A.

If there are garbage characters on the LCD, the LCD connection may be loose. If this occurs, unplug then reconnect power to Edit Suite. If the display still shows garbage, contact your dealer or Videonics to have the unit repaired.

12 EDL full

An attempt to create or copy an event was done, but there are not enough empty events in the EDL to complete the create/copy.

The maximum number of events in the EDL is 250. If you need more than 250 events and have access to a computer, use the Setup/Export function to save the EDL on a computer, then delete the existing EDL via the Setup/EDL function. If you do not have access to a computer, you will have to delete some events before new events can be created.

13 EDL empty

The last remaining event in the EDL was deleted.

This is an advisory message only. After pressing [OK] to clear the message, the NEW menu displays.

14 EDL corrupt

After a [CUT] or a [SHIFT]+[CUT], the EDL was found to be unusable.

The entire EDL will need to be deleted. Use the Setup/EDL function to delete it. If you have a copy of the EDL stored on a PC, use the Setup/Import function to restore the EDL.

15 VCR table too large

An attempt to add a VCR table using the NEWVCR function was made, but there is not enough memory left in Edit Suite to add the table.

Any single table you have been provided is small enough to fit in memory; however, if you have added other tables via the NEWVCR function, the combination may exceed memory limits. The only way to make room for the new table is to delete the existing tables. To do this, you must fully reset your unit which will delete all EDL and configuration data. If you need to do this, unplug Edit Suite, then press and hold [SHIFT]+ [ALL STOP] while reconnecting power to Edit Suite.

16 No valid group found

[SHIFT]+[AUTO REC] was pressed, but there are no events in the EDL.

Clear the message. The NEW menu displays. If you were attempting to do an assemble edit, press [REC] only instead of [SHIFT]+[AUTO REC].

17 Invalid primary tile

A Source (SRC) Event with no duration was encountered during a preview or auto-record.

Enter a duration for the Source Event.

18 No VITC found

Edit Suite attempted to read VITC time code but was unable to do so.

If the TCSRC parameter is set to INT (internal), ensure that the VCR/ camcorder is set to send VITC instead of LTC, RCTC or counter.

If the TCSRC parameter is set to EXT, ensure that a video cable is attached from the VCR's video out to the correct Time Code In port on Edit Suite.

Ensure that there is VITC on your tape. If your VCR can show VITC on its counter, use that to do your verification. If you have a monitor with a vertical hold, you can adjust the hold to see the VITC (a series of short vertical lines) at the top of the video.

If the TCSRC parameter is set to EXT, check the STABLE Advanced parameter. If it is not set to 45, change it to 45. If it is already 45, increase its value to 60 and try again. If you increase STABLE, also increase the PLY (play) parameter by two (2) seconds and the REW (rewind) parameter by four (4) seconds.

19 No LTC found

Edit Suite attempted to read LTC time code but was unable to do so, or TCSRC=EXT and TC=NONE or RCTC.

If TC=NONE or RCTC, the TCSRC parameter must be set to INT (internal).

If TC=LTC and TCSRC=INT (internal), ensure that the VCR/ camcorder is set to send LTC instead of VITC, RCTC or the Real Time Counter.

If TC=LTC and TCSRC=EXT, ensure that an audio cable is attached

from the VCR's Time Code Out or Audio OUT channel that contains the LTC to the correct Time Code IN port on Edit Suite.

Ensure that there is LTC on your tape. If your VCR can show LTC on its counter, use that to do your verification. Otherwise, connect the LTC cable directly to the audio IN on your monitor and listen for the LTC. It will sound like a high-pitched squeal.

If the TCSRC parameter is set to EXT, check the STABLE Advanced parameter. If it is not set to 45, change it to 45. If it is already 45, increase its value to 60 and try again. If you increase STABLE, also increase the PLY (play) parameter by two (2) seconds and the REW (rewind) parameter by four (4) seconds.

20 VCR not specified

During a preview or an auto-record, either an event referenced a VCR port that has a PROTO set to NONE, or VCRR's PROTO is set to NONE.

In the SETUP/CONFIG menu, check the PROTO setting for each VCR attached to Edit Suite. If the settings are correct, ensure that none of the events reference a VCR (A/B/C/D) that is not defined in CONFIG.

21 No MX-1 found

Edit Suite attempted to communicate with a Videonics MX-1 but was unable to do so. This usually occurs during a preview or auto-record, or when the GPI-M key is pressed.

1. Make sure your GPI cable is a stereo cable.
2. If you are not using an MX-1, change the CONFIG/GPI-M setting from MX-1 to either MIXER (if a third-party mixer/switcher is used) or to GPI (if a GPI device is used, or if no mixer/switcher or MX-1 is used).
3. If you have an MX-1, verify that the GPI cable is connected to Edit Suite's GPI-M port and to the MX-1's GPI port. Ensure that the MX-1 is turned on. If it is, cycle its power.

<p>22</p>	<p>Invalid ED#</p> <p>The EDL number entered in the GO TO function ([GO TO]+[OK]) does not exist in the EDL.</p> <p>If you know the EDL number, try the GO TO function again. Otherwise, use the up/down arrow keys to search through the EDL for the event.</p>
<p>23</p>	<p>Insert not available</p> <p>An INS (insert) event is specified, but the VCRR configuration indicates that the record VCR cannot do inserts.</p> <p>If the record VCR can do inserts, change the INS parameter in SETUP/CONFIG/VCRR from 0 to 1. If the record VCR cannot do inserts, delete the INS Events from the EDL.</p>
<p>24</p>	<p>Split not available</p> <p>A SPLT (split insert) event is specified, but the VCRR configuration indicates that the record VCR cannot do split inserts.</p> <p>If the record VCR can do split inserts, change the SPLT parameter in SETUP/CONFIG/VCRR from 0 to 1. Also ensure that the INS (insert) parameter is set to 1. If the record VCR cannot do split inserts, delete the SPLT Events from the EDL.</p>

Error Message Display Format

A Setup parameter–MSGs–determines whether error messages will display message numbers only or message numbers and message text. The following are example of both choices.

<p>ERROR 10</p>

<p>ERROR VCR number not 10 available</p>
--

Message Number Only Message Number and Text

To change the MSGS parameter–

1. Display Setup Menu 2 by pressing [SETUP], then pressing [down arrow] twice.



Setup Menu 2 Error Messages Parameter

2. Move the cursor to MSGS and press [OK] to display the Error Messages parameter.
3. Press [CHG] to cycle between the two choices: 0=do not include the text; 1=include the text.
4. Press [SETUP] twice to exit setup and return to the EDL.

Troubleshooting

The following are trouble conditions you may encounter and the action to take to prevent or work around these conditions.

Troubleshooting Table

Trouble	Action
Asterisks (***) display in the time code field instead of time code.	Edit Suite is not receiving time code or Real Time Counter information from the selected VCR. Verify that the VCR is turned on, the VCRs counter shows a time value, and all connections between the VCR and Edit Suite are secure and correct. Verify that the PROTO (protocol), VCR number, TCSRC, and TC Configuration Parameters are set correctly. Refer to Appendix A for help in determining these settings. For RS-

	<p>232 VCRs, also check the communication speed and the character format.</p> <p>The VCR may be in a high speed rewind or fast forward and not report the time code. For RCTC, use a different table (121-126).</p> <p>The tape may have no video recorded on the portion that is playing. Move to a portion of the tape that contains video.</p>
<p>Beeper doesn't beep.</p>	<p>Press [SETUP] to display Setup Menu 1. Press [down arrow] twice to display Setup Menu 2. Move the cursor to BEEPER and press [OK]. If either value is set to 0, press [CHG] to change it to 1. Press [OK] to accept the change and return to the Setup Menu, then press [SETUP] to return to the EDL.</p>
<p>During a Preview or Auto-Record, Edit Suite pauses in the middle of a scene.</p>	<p>This is probably due to a Match Frame Edit. If you have back-to-back transitions in the EDL, Edit Suite needs to pause in the middle of some scenes so that it can correctly preposition the video for the following scene. See <i>Match Frame Edits</i> in the MX1 Events section of Chapter 5.</p>
<p>Edit Suite is slow to respond to button presses.</p>	<p>For any unused port, change the PROTO parameter to NONE.</p>
<p>EDL Event numbers are not in sequence.</p>	<p>This does not matter to Edit Suite—it will process the events based on their order in the EDL, not on their event numbers.</p> <p>To renumber the events, press [GO TO] +[SHIFT]+ [CHANGE].</p>
<p>Frames in the LCD time code display do not increment while the VCR is playing.</p>	<p>If EXT VITC or LTC is used, or if the Real Time Counter for the VCR/camcorder does not show frames, Edit Suite will not update the frame field in the time code display until Play, In, Out, GPI-M or GPI-T is pressed.</p>

<p>GPI-triggered title was not recorded.</p>	<p>Check the start time for the GPI Event. If it is outside the IN and OUT times for the corresponding scene, it will not be triggered. If the event occurs close to the OUT time, the title may not be able to play before the recorder is paused. Move the GPI time ahead a few seconds.</p> <p>See <i>GPI Events</i> in Chapter 5 for more information.</p>
<p>Jog fails to control the VCR.</p>	<p>Does the VCR/camcorder have jog capabilities? If not, Edit Suite will not be able to jog the video.</p> <p>Ensure the VCR is powered on and that the VCRs counter displays a time code value. Select a different source and then reselect the current source.</p> <p>Turn the shuttle past the Pause position and then back to Pause. If this does not work, try pressing the PLAY transport key.</p> <p>If the jog worked previously, remove and then reattach Edit Suite's power cord. Note: Before removing power from Edit Suite, disconnect Edit Control cables to VCRs with PANA protocol.</p>
<p>Inaccurate scene</p>	<p>If you have not already done the fine-tuning procedures in Chapter 7, do them.</p> <p>If the tuning procedures do not fix the problem, increase the PLY(play) Advanced Parameter by five (5) seconds, but be sure that the REW (rewind) parameter value is equal to or greater than PLY and that both are less than the FFD (fast forward) parameter.</p>
<p>IN OFFSET has no effect on the in-point accuracy.</p>	<p>The IN OFFSET for Play VCRs adjusts the start time for the "B" source in an A/B Roll. See Chapter 7, <i>Fine Tuning</i>.</p>

<p>INS (Insert) Event was created instead of a Scene Event.</p>	<p>The Record VCR (R) was selected when IN or OUT was pressed. Delete the Insert Event, then select a source VCR and press [IN] or [OUT].</p>
<p>LCD Display is hard to read.</p>	<p>Adjust the LCD contrast. To do this press [SETUP] to display Setup Menu 1; with the cursor on LCD, press [OK] to display the LCD Contrast screen. Press [CHG] to access change mode, then turn the jog (shuttle must be in pause) until the desired contrast setting is reached. Press [OK] to save the setting and return to Setup Menu 1. Press [SETUP] to return to the EDL.</p>
<p>Missed scene.</p>	<p>Scene may be too close to the start of the tape. Scenes that start earlier than 45 seconds or one minute from the start of the tape should not be used.</p> <p>If an A/B Roll is specified, the "A" or "B" scene may be shorter than the duration of the transition. Either lengthen the scene or increase the speed (decrease the duration) of the transition.</p> <p>If neither of the above apply, increase the PLY (play) Advanced Parameter by five (5) seconds, but be sure that the REW (rewind) parameter value is equal to or greater than PLY and that both are less than the FFD (fast forward) parameter.</p> <p>If external VITC or LTC is not being used, instead of increasing the PLY parameter you can decrease the STABLE parameter from 45 to 15.</p>
<p>MX-1 Color Is Not Updated.</p>	<p>If a Source (SRC) Event with an MX-1 Color is the first event in an auto-record, either the Record VCR must be put in Record Pause manually before the auto-record is started, or the MX-1 must be set up manually with the correct color.</p>

<p>OUT Time cannot be removed from a scene event.</p>	<p>Delete the event, create a new event, and reenter the IN time.</p>
<p>Record VCR using VITC or LTC rewinds to the beginning or fast forwards to the end of the tape after the first scene is recorded.</p>	<p>1. The VITC or LTC on the record VCR tape does not match the values being sent to Edit Suite. Check the VCR's VITC/LTC regeneration settings.</p> <p>2. VITC or LTC is specified for the record VCR, but the VCR does not write LTC or VITC. This is true of VCRs using PANA or LANC protocol. Select TCSRC=INT and TC=NONE for VCRR.</p>
<p>Scene accuracy is off.</p>	<p>Follow the procedures in Chapter 7, <i>Fine Tuning</i>.</p>
<p>SRC event is short.</p>	<p>If a Source (SRC) Event is the first event in an auto-record, the Record VCR must be put in Record Pause manually before the auto-record is started. Otherwise, the SRC event will be short by two or three seconds.</p>
<p>VCR cannot be controlled by Edit Suite.</p>	<p>Check your VCR documentation for a Master/Slave switch; select Slave. Check for a Local/Remote switch; select Remote. (Note that some VCRs reset a Master/Slave Menu choice to Master when power is removed from the VCR.)</p> <p>For RS-232 VCRs, if a null modem is not being used, add one. If it is being used, try removing it.</p> <p>See Step 9 of Chapter 3, <i>Getting Started</i>.</p>
<p>VCR cannot be controlled or powered off with its Control Keys.</p>	<p>Remove the Edit Control cable from the VCR. Reconnect the cable when you are ready to use Edit Suite again.</p>

VCR starts to rewind to a scene but goes into Play before it reaches the scene, or the VCR rewinds to the beginning of the tape.

Edit Suite is not receiving time code or Real Time Counter information from the VCR while it is in Rewind. Look at the counter on the VCR while it is rewinding. If it stutters or goes blank, Edit Suite will not receive the time code value. If RCTC is used with LANC protocol, select VCR table 121-126 (see Appendix A).

If time code is being used, the time code may not be continuous or may be missing from a portion of the tape. If possible, restripe the tape. If this is not possible, use the Real Time Counter instead of Time Code by setting TCSRC to INT and TC to NONE.

Vertical phase synchronization problems on recordings.

If the Record VCR has a Time Base Corrector, turn it off.

Appendix A ◦ VCR Tables

This appendix describes each of the VCR tables available with Edit Suite. There is a separate table for each protocol—PANA, LANC, 422, 232 and IR.

Each table provides a general description of the protocol and information that will help you determine the settings for the VCR, TCSRC and TC Configuration Parameters.

The **bolded** numbers in each table are the primary VCR numbers used for that protocol. The other VCR numbers in the table provide alternative choices you can use depending on the characteristics of your VCR or your preference for jog and shuttle control.

PANA (Panasonic Control-M) Protocol

VCR Table #	DESCRIPTION
PANA	<p>VCR table 001 is the primary table for VCRs and camcorders using Panasonic Control-M protocol. The other tables in the PANA group change the performance of the jog and/or shuttle.</p> <p>If the videotapes used with a PANA VCR are not striped with VITC or LTC, select TCSRC=INT and TC=NONE in the configuration parameters.</p> <p>If VITC or LTC is striped on the tapes, the time code must be delivered to Edit Suite via an audio (LTC) or video (VITC) cable attached to Edit Suite's Time Code IN port. In this case, select TCSRC=EXT and TC=VITC or LTC.</p>
001	<p>Primary table for VCRs and camcorders using PANA protocol. The table has two shuttle speeds between pause and play and two speeds between pause and reverse play. It also supports all other transport control functions.</p> <p>For VCRs and camcorders with jog (frame advance) capabilities, each slow turn of the jog advances/rewinds the video approximately two frames. Faster turns increase the speed up to a maximum of Play speed.</p>
002	Same as PANA 001, but with three speeds between pause and play and pause and reverse play. Table 002 also increases the number of frames per slow turn of the jog to four.
011	Same as PANA 001, but with the jog remaining in jog speed instead of increasing in speed the faster it is turned.
111	Same as PANA 001, but each slow turn of the jog advances/rewinds the video approximately four frames.
112	Same as PANA 001, but each slow turn of the jog advances/rewinds the video approximately seven and one half frames.

LANC (Control-L) Protocol

VCR Table #	DESCRIPTION
LANC	<p>LANC tables 001, 002, 007, and 012 are the primary tables for VCRs and Camcorders using LANC protocol. (Read the RCTC comments for tables 121-126 below.)</p> <ul style="list-style-type: none"> • Table 001 works for most full-featured VCRs with jog and shuttle capabilities. • Table 002 works for most camcorders and VCRs that do not have reverse jog/shuttle capabilities (review or reverse play only). • Table 007 is for VCRs/Camcorders – like the CCD-V5000 – that need continuous commands sent to them to stay in Cue and Review. • Table 012 is for VCRs/Camcorders – like the Canon UCS-1 – that need waiting periods added between each command sent to them. <p>The other tables in the LANC group change the performance of the jog/shuttle.</p> <p>For VCRs and camcorders that do not have Time Code, select TCSRC=INT and TC=NONE. If RCTC is used, select TCSRC=INT and TC=RCTC. If VITC or LTC time code is striped on the tapes, the time code must be delivered to Edit Suite via an audio (LTC) or video (VITC) cable attached to the Time Code IN port. In this case, select TCSRC=EXT and TC=VITC or LTC.</p> <p>If RCTC is used, be sure the tape is striped. You can stripe a source tape by fully rewinding the tape then using the Play-Write or Record-Write function. Check your VCR manual for details.</p> <p>For RCTC, if the time code counter on the VCR/camcorder goes blank or skips when in Rewind or Fast Forward, instead of selecting the primary tables, use tables 121 - 126. Many VCRs with RCTC do not update the time code when the VCR is in Rewind and/or Fast Forward mode. Since Edit Suite needs this information during searches and auto-records, the rewind and fast forward commands have been changed to fast play (cue) and fast reverse play (review) commands. This way Edit Suite is able to keep track of the time code. With tables 121-126, pressing the FFWD and REWIND transport keys will do cues and reviews only.</p>
001	<p>Full-featured table: Works with most LANC VCRs that have forward and reverse jog/shuttle capabilities and two or more speeds between pause and play and between pause and reverse play. Edit Suite provides two speeds between pause and play and two speeds between pause and reverse play.</p> <p>For VCRs with jog capabilities, each slow turn of the jog advances/rewinds the video approximately three frames. Faster turns increase the speed up to a maximum of play speed.</p>
121	<p>Same as LANC- 001, except for VCRs and camcorders using RCTC if the VCR counter goes blank or skips time during Rewind or Fast Forward. (Edit Suite will show asterisks in the time code field if it cannot read the counter/time code information.)</p>
111	<p>Same as LANC-001, except each slow turn of the jog advances/rewinds the video approximately five frames.</p>
112	<p>Same as LANC-001, except each slow turn of the jog advances/rewinds the video approximately 15 frames.</p>
126	<p>Same as LANC-111, except for VCRs and camcorders using RCTC if the VCR counter goes blank or skips time during Rewind or Fast Forward. (Edit Suite will show asterisks in the time code field if it cannot read the counter/time code information.)</p>

002	<p>Most camcorders and some VCRs use this table. Most of these VCRs/camcorders do not have any slow-reverse capabilities, so this table converts all reverse jog and shuttle movements to Fast Reverse Play (Review). All of the forward jog and shuttle capabilities of table 001 are available.</p> <p>If the VCR/camcorder does not stay in Review when the Shuttle is turned counterclockwise, use table 003. If it does not stay in Review when the shuttle is turned counterclockwise and it does not stay in Fast Play (Cue) when the shuttle is turned to a position beyond Play, use table 007.</p>
122	Same as LANC-002, except for VCRs and camcorders using RCTC if the RCTC skips or blanks during Rewind or Fast Forward.
004	Same as LANC-002, except each slow clockwise turn of the jog advances the video approximately 5 frames.
003	Same as LANC-002, except the Review command is sent continuously. Use this table or Table 005 if the Review command in Table 002 does not work properly when the shuttle is turned counterclockwise.
123	Same as LANC-003, except for VCRs and camcorders using RCTC if the VCR counter goes blank or skips time during Rewind or Fast Forward. (Edit Suite will show asterisks in the time code field if it cannot read the counter/time code information.)
005	Same as LANC-003 except there is only one shuttle speed between pause and play.
006	Minimum feature set: For use with VCRs and camcorders that support stop, pause, play, cue, review, fast forward, and rewind only.
007	<p>This table is for VCRs and camcorders – like the Sony CCD-V5000 – that need continuous commands sent to them to remain in Fast Play (Cue) and Fast Reverse Play (Review) modes.</p> <p>If this table does not work for your VCR/camcorder, use table 012.</p>
124	Same as LANC-007, except for VCRs and camcorders using RCTC if the VCR counter goes blank or skips time during Rewind or Fast Forward. (Edit Suite will show asterisks in the time code field if it cannot read the counter/time code information.)
012	Some VCRs/camcorders – like the Canon UCS-1 – require a waiting period between the commands that are sent to them. For example, to change some VCRs from Rewind to Cue, Edit Suite needs to send a Play command followed by a Cue command. Many VCRs can accept these commands with a minimal pause between the two commands. Others require a waiting period of up to one second. This table supports VCRs and camcorders that require this longer waiting period.
125	Same as LANC-012, except for VCRs and camcorders using RCTC if the VCR counter goes blank or skips time during Rewind or Fast Forward. (Edit Suite will show asterisks in the time code field if it cannot read the counter/time code information.)
010	Same as LANC-012 but without the waiting period between commands. Works for most other Canon camcorders.

RS-422 Protocol

VCR Table #	DESCRIPTION
RS-422	<p>Table 001 is the primary table for RS-422. It works for most VCRs and camcorders using RS-422 protocol. The other tables in the group change the performance of the jog and/or shuttle.</p> <p>If the VCR has a step/linear choice for the jog or shuttle, select step.</p> <p>Most RS-422 VCRs send time code or counter information over the Edit Control cable, so set the TCSRC configuration parameter to INT. Set the TC parameter to the type of time code sent by the VCR. If the VCR can send different types of time code, be sure the time code you select in Edit Suite is the same type that will be sent by the VCR.</p> <p>Some RS-422 VCRs have Real Time Counters only. If you have a VCR like this but also have VITC or LTC striped on your tape, change the TCSRC to EXT and use table 021. The time code must be delivered to Edit Suite via an audio (LTC) or video (VITC) cable attached to the Time Code IN port. In this case, change TCSRC to EXT and change TC to VITC or LTC.</p>
001	Works with most VCRs using RS-422 protocol, and includes shuttle speed down to 1/30 x Play. Turning the jog slowly advances/rewinds the video approximately 3 frames per revolution.
002	Same as 422-001, except this table supports shuttle speeds down to 1/10 x Play.
003	Same as 422-002 but the jog stays in jog mode instead of stepping up to Play speed.
004	Same as 422-002, but turning the jog slowly advances/rewinds the video approximately 5 frames per revolution.
005	Same as 422-002, but turning the jog slowly advances/rewinds the video approximately 7 1/2 frames per revolution.
011	Same as 422-001, but with different steps for the jog between Jog and Play.
021	<p>This table is normally used only if LTC or VITC time code will be sent to Edit Suite via the Time Code In ports instead of over the Edit Control cable.</p> <p>If this table is used, Edit Suite will control the search process (whereas with other 422 tables, the VCR controls the search). Because of this, you may need to adjust the INPUT OFFSET parameter during the Fine Tuning process. See Chapter 7, <i>Fine Tuning</i>, for the procedure to use. Also, change the FFD Advanced Parameter to 00:45.</p>

RS-232 Protocol

VCR Table #	DESCRIPTION
RS-232	<p>There are three primary tables for VCRs using RS-232 protocol: Table 001 is for Sony VCRs; Table 003 is for Panasonic VCRs; Table 004 is for JVC VCRs.</p> <p>If the VCR has a step/linear choice for the jog or shuttle, select step.</p> <p>Most RS-232 VCRs send time code or counter information over the Edit Control cable, so set the TCSRC configuration parameter to INT. Set the TC parameter to the type of time code sent by the VCR.</p> <p>Some RS-232 VCRs have Real Time Counters only. If you have a VCR like this but also have VITC or LTC striped on your tape, change the TCSRC to EXT and use table 021 (Sony), 006 (Panasonic), or 024 (JVC). The time code must be delivered to Edit Suite via an audio (LTC) or video (VITC) cable attached to the Time Code IN port. In this case, change TCSRC to EXT and change TC to VITC or LTC.</p>
001	<p>Sony: This is the primary table for Sony VCRs using RS-232 protocol. Table 005 is an alternate table that was designed for the UVW-1400.</p> <p>Turning the jog slowly advances/rewinds the video approximately 3 frames per revolution. Increasing the rate causes the VCR to increase its jog speed up to a maximum of Play speed.</p> <p>Do not use this table if TCSRC=EXT. Use table 021 instead.</p>
005	<p>Sony: UVW-1400. The 1400 requires slightly different commands than the Table 001 commands to determine the VCR status and time code information. If table 001 does not work for you, try this table.</p> <p>If you select this table, watch Edit Suite's LCD while the VCR is playing to ensure that the time code displays properly. If you see alpha characters or values that are out of range, use table 001.</p>
021	<p>Sony: This table is normally used only if LTC or VITC time code will be sent to Edit Suite via the Time Code In ports instead of from the Edit Control cable.</p> <p>If table 021 is used, Edit Suite will control the search process (whereas with other 232 tables, the VCR controls the search). Because of this, you may need to adjust the INPUT OFFSET parameter during the Fine Tuning process. See Chapter 7 for the procedure to use. Also, change the FFD Advanced Parameter to 00:45.</p>
011	<p>Sony: Same as 001, except with a slightly different progression for the jog when transitioning from slow jog to faster jog.</p>
031	<p>Sony: Same as 001, except each slow turn of the jog advances the video approximately 7 1/2 frames.</p>

003	<p>Panasonic: This is the primary table for Panasonic VCRs using RS-232 protocol.</p> <p>Turning the jog slowly advances/rewinds the video approximately 3 frames per revolution. Increasing the rate causes the VCR to increase its jog speed up to a maximum of Play speed.</p> <p>Do not use this table if TCSRC=EXT. Use table 006 instead.</p>
006	<p>Panasonic: This table is normally used only if LTC or VITC time code will be sent to Edit Suite via the Time Code In ports instead of from the Edit Control cable.</p> <p>If this table is used, Edit Suite will control the search process (whereas with other 232 tables, the VCR controls the search). Because of this, you may need to adjust the INPUT OFFSET parameter during the Fine Tuning process. See Chapter 7 for the procedure to use. Also, change the FFD Advanced Parameter to 00:45.</p>
013	<p>Panasonic: Same as 003, except with a slightly different progression for the jog when transitioning from slow jog to faster jog.</p>
033	<p>Panasonic: Same as 003, except each slow turn of the jog advances the video approximately 7 1/2 frames.</p>
004	<p>JVC: This is the primary table for JVC VCRs using RS-232 protocol.</p> <p>Turning the jog slowly advances/rewinds the video approximately 3 frames per revolution. Increasing the rate causes the VCR to increase its jog speed up to a maximum of Play speed.</p> <p>Do not use this table if TCSRC=EXT. Use table 024 instead.</p>
024	<p>JVC: This table is normally used only if LTC or VITC time code will be sent to Edit Suite via the Time Code In ports instead of from the Edit Control cable.</p> <p>If this table is used, Edit Suite will control the search process (whereas with other 232 tables, the VCR controls the search). Because of this, you may need to adjust the INPUT OFFSET parameter during the Fine Tuning process. See Chapter 7 for the procedure to use. Also, change the FFD Advanced Parameter to 00:45.</p>
014	<p>JVC: Same as 004, except with a slightly different progression for the jog when transitioning from slow jog to faster jog.</p>
034	<p>JVC: Same as 004, except each slow turn of the jog advances the video approximately 7 1/2 frames.</p>

VCR Infrared Code List

Akai	112, 125, 022, 060, 067	MultiTech	043
Astra	025	NEC	111, 124, 006, 019, 059
Audio Dynamics	006	Nordmende	071, 072, 084, 086, 093, 099
Aiwa	043, 090	Olympus	010
Bang & Olufsen	008, 079	Orion	040, 087, 097, 098, 118
Blaupunkt	001, 002, 004, 005, 007, 010, 020, 033, 051, 055, 068	Panasonic	001, 002, 004, 007, 010, 055, 068
Broksonic	053	Pentax	010, 123, 056
Canon	103, 119, 122, 010, 021, 041, 050	Philco	010, 116, 037, 043
Cape Hart	116, 037	Philips	010, 032, 069, 089, 092
Curtis-Mathes	010	Pioneer	010, 030
Daewoo	116, 127, 037, 058, 096	Portland	116, 037
Daytron	116, 037	Quasar	010, 103, 021
DBX	006	Radio Shack	010, 101, 026, 044
Dumont	025	RCA	102, 103, 128, 021, 029, 064
Dynatech	043	Realistic	010
Electroponic	006	Saba	071, 072, 084, 086, 093, 099
Emerson	010, 023, 028, 035, 053, 114	Saisho	117, 039
Ferguson	006, 048, 049, 052, 070, 080, 083	Samsung	025
Fisher	109, 113, 126, 016, 024, 061	Sansui	006
Funai	043	Sanyo	110, 013
General	120, 121, 046, 047	Scott	012, 042, 053
General Electric	103, 010, 021	Sentra	116, 037
Go Video	065, 066	Sharp	027, 044, 063
Goldstar	101, 104, 014, 026	Shintom	115, 036
Grundig	010, 032, 038, 073, 088, 091, 095	Siemens	085, 094
Hitachi	105, 108, 003, 010, 048, 057	Signature	010, 027
Instant Replay	010	Sony	005, 020, 033, 051
ITT	006	Sound Design	043
J C Penney	101, 010, 026	Sylvania	010
Jensen	006	Symphonic	011, 043
JVC	006, 048, 052	Tatung	006
Lloyds	043	Teac	043
Loewe	081	Teknika	043
Logik	043	Telefunken	045, 071, 072, 078, 084, 086, 093, 099
Magnavox	104, 010, 014, 055, 100	Thomas	043
Magnin	025	Thomson	071, 072, 078, 084, 086, 093, 099
Marantz	124, 059	TMK	006, 012
Matsui	082	Toshiba	106, 107, 015, 017
Memorex	010	Totevision	025
MGA	034	Video Concepts	034
Minolta	105, 003	XR-1000	043
Mitsubishi	009, 018, 031, 034, 054	Yamaha	006
Montgom. Ward	010, 027	Zenith	062

Appendix B • Cables and Cable Pinouts

This appendix provides diagrams and part numbers for the cables available from Videonics and PC communication cables. It also provides cable pinout charts for the Videonics RS-232/RS-422 cable and the cable required for Sanyo GVR-S955 VCRs.

Sony LANC (Control-L Submini): Videonics Part No.: CBLA-0020-01

8-pin DIN Sony LANC (Control-L) 3-conductor sub-mini

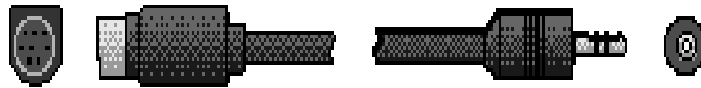

Sony LANC (Control-L 5-Pin): Videonics Part No.: CBLA-0019-01

8-pin DIN Sony 5-pin (Control-L) DIN



Panasonic LANC (Control M 5-pin): Videonics Part No.: CBLA-0014-02

8-pin DIN Panasonic 5-pin (Control-M) DIN



RS-232/422: Videonics Part No.: CBLA-0042-01

A 9-pin to 25-pin converter is also needed for RS-232, plus a null modem for RS-232 except Panasonic. They are available at computer parts stores.

8-pin DIN RS-232/422 DB-9



Infrared Wand: Videonics Part No.: ASYS-0004-03

2-conductor mini IR wand



COMPUTER RS-232C for Personal Computers

A standard RS-232 serial communication cable is used to connect a PC to Edit Suite. The computer end of the cable may be a DB-9 or a DB-25. These are available at most computer parts stores.

RS-232C DB-9 RS-232C DB-9



COMPUTER RS-232C for Macintosh Computers

A standard RS-232 serial communication cable is used to connect a Macintosh to Edit Suite. The cable is an 8-pin DIN to a DB-9. These are available at most computer parts stores. The Videonics RS-232/422 cable (CBLA-0042-01) may also be used.

8-pin DIN RS-232C DB-9



GPI CABLES: Videonics Part No.: CBLA-0041-01

These are standard stereo mini-to-mini cables available at computer and audio supply stores.

3-conductor mini 3-conductor mini

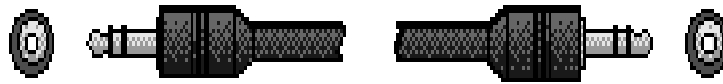

TIME CODE IN : Videonics Part No.: CBLA-0001-02

These are standard audio/video cables with RCA jacks.

RCA-style RCA-style



Cable Pinout Charts

The following are the cable pinouts used to make RS-232/422 cables. For most RS-232 VCRs, you will also need a 9-pin to 25-pin converter and, for most RS-232 VCRs except Panasonic, a null modem.

The Sanyo cable pinout is for the RS-422 auto-sensing communication package used with the GVR-S955.



RS-232/422 Cable

RS-232/422 Cable Pinout Chart

CBLA-0042-01

	VCR CONTROL		DB-9	
	PIN 1	—	PIN 7	
	PIN 2	—	PIN 8	
	PIN 3	—	PIN 3	
	PIN 4	—	PIN 5	
	PIN 5	—	PIN 2	
	PIN 6	—	PIN 4	
	PIN 7	—	PIN 6	
	PIN 8	—	PIN 1	
		—	PIN 9	
	HOUSING		HOUSING	

Sanyo GVR-S955 RS-422 Cable Pinout Chart

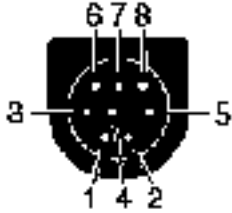
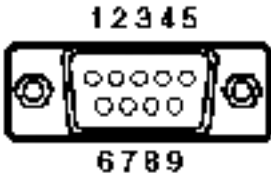
	YCR CONTROL	DB-9																																				
	<table style="width: 100%; border-collapse: collapse;"> <tr> <td style="width: 50%;">PIN 1</td> <td style="width: 5%; text-align: center;">—</td> <td style="width: 45%;">PIN 7</td> </tr> <tr> <td>PIN 2</td> <td style="text-align: center;">—</td> <td>PIN 8</td> </tr> <tr> <td>PIN 3</td> <td style="text-align: center;">—</td> <td>PIN 3</td> </tr> <tr> <td>PIN 4</td> <td style="text-align: center;">—</td> <td>PIN 6</td> </tr> <tr> <td>PIN 5</td> <td style="text-align: center;">—</td> <td>PIN 2</td> </tr> <tr> <td>PIN 6</td> <td style="text-align: center;">—</td> <td></td> </tr> <tr> <td>PIN 7</td> <td style="text-align: center;">—</td> <td></td> </tr> <tr> <td>PIN 8</td> <td style="text-align: center;">—</td> <td>PIN 4</td> </tr> <tr> <td></td> <td></td> <td>PIN 5</td> </tr> <tr> <td></td> <td></td> <td>PIN 1</td> </tr> <tr> <td></td> <td></td> <td>PIN 9</td> </tr> <tr> <td>HOUSING</td> <td style="text-align: center;">—</td> <td>HOUSING</td> </tr> </table>	PIN 1	—	PIN 7	PIN 2	—	PIN 8	PIN 3	—	PIN 3	PIN 4	—	PIN 6	PIN 5	—	PIN 2	PIN 6	—		PIN 7	—		PIN 8	—	PIN 4			PIN 5			PIN 1			PIN 9	HOUSING	—	HOUSING	
PIN 1	—	PIN 7																																				
PIN 2	—	PIN 8																																				
PIN 3	—	PIN 3																																				
PIN 4	—	PIN 6																																				
PIN 5	—	PIN 2																																				
PIN 6	—																																					
PIN 7	—																																					
PIN 8	—	PIN 4																																				
		PIN 5																																				
		PIN 1																																				
		PIN 9																																				
HOUSING	—	HOUSING																																				

Appendix C • Equipment Hookup

Edit Suite is compatible with a wide range of VCRs, camcorders and editing equipment, such as video mixers and switchers, title generators, video processors and audio mixers. Edit Suite can be connected in multiple ways, depending on the equipment you use.

Connections—Overall Concept

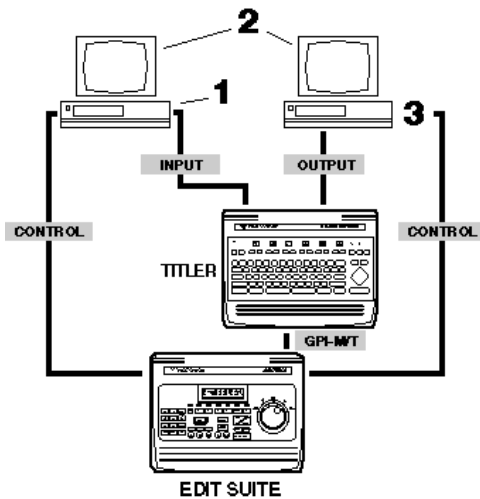

A typical single-source, A-A Roll system showing Edit Suite connected with a TitleMaker 2000. Any other GPI-compatible titler may be substituted.

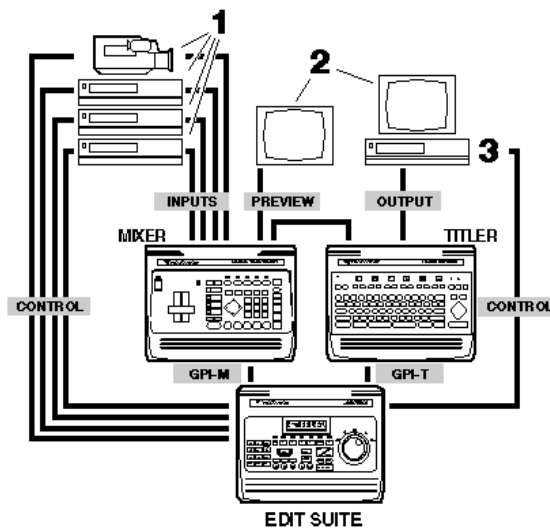

A typical A/B Roll system showing Edit Suite connected with a Digital Video Mixer and TitleMaker 2000. Any other GPI-compatible mixer or titler may be substituted.

Edit Suite can control up to five VCRs/camcorders, (four play and one record). This appendix describes how to connect the time code inputs and make the VCR control connections.

What You'll Need

1 One or more Play VCRs/camcorders or other video source(s). The audio/video outputs from these sources will go directly to your mixer, titler, or record VCR—depending on the equipment in your setup. No audio or video connections to Edit Suite are used unless LTC or VITC time code is used and then only if the time code is not sent through the Edit Control cable.

2 An output monitor. You will need a video monitor to view your video footage.

The **output monitor** will be connected to your recording VCR (3), or you can use any arrangement that allows you to view tapes played on the VCR. Required connections for any monitor hookup depend on the VCR.

If you are not using a mixer, this may be the only monitor you need. If you have a preference for viewing the source material on its own, you can connect another monitor to the Play VCRs.

If you are using an MX-1, you will need another video monitor connected to the MX-1's Preview output. The MX-1 allows any connected video source (up to a total of four) to be viewed using this PREVIEW monitor.

If you are using a third-party mixer or switcher, you may want to add monitors to each of your Play VCRs in order to view their material separately.

3 A Record VCR. This VCR will ideally have an edit control port and flying erase heads for smooth edit breaks. Infrared support is also available for those Record VCRs without wired control capability.

- **Cables.** You will need one edit control cable for each VCR with an edit control jack, one IR wand if your record VCR uses IR control, one GPI cable for a mixer (if you have a mixer) and one GPI cable for a titler (if you have a titler or character generator). Make sure the GPI cable you use with the MX-1 is a stereo cable.

You will also need audio and video cables to connect the play sources to the mixer, titler, and record VCR plus cables to attach the outputs to your monitor(s).

Optional Cables

- Additional audio and video cables for routing time code to Edit Suite.
- Serial RS-232C computer cable for importing and exporting EDLs.

Appendix B provides figures and part numbers for each cable you may need.

Connecting Power, VCRs, Monitors

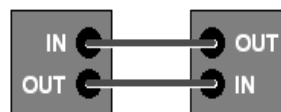

Hint: Always connect the Out jack of one device to the In jack of the next. Never connect two outputs together.

If you have not already configured Edit Suite for your VCRs, refer to Chapter 3, *Getting Started*, and complete Steps 1 through 7 before continuing with your equipment hookup.

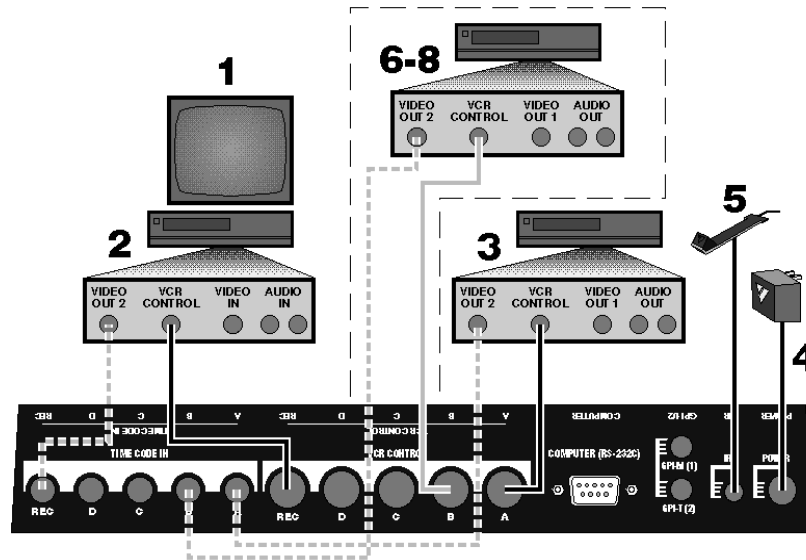

- **The power supply**

Connect the power supply (4) to the POWER input and plug it into a working power outlet. Be sure to use the power supply that came with Edit Suite. Other similar-looking power supplies, including those with other Videonics products, may damage the unit and void the warranty.

When first connected, Edit Suite will start up automatically, turn on the LCD display, the power indicator, and one or two of the LEDs, then run through its configuration routine. After the configuration routine is complete, the Demo screens, the NEW menu, or the first event in your EDL will display, depending on parameter settings and whether or not there are any events in the EDL.

- **The VCR control cables**

Unless your record VCR uses IR control, connect the appropriate edit control cable from the control port of your record VCR (2) to the VCR CONTROL REC port on Edit Suite. If IR control is used, attach the IR wand to the IR jack (5) and position the wand as shown in Chapter 3, *Getting Started*. Next, connect a video monitor (1) to the Record VCR, as described in the manual that came with the VCR. You can use S-video, composite, or RF (cable/antenna) cables to connect the Record VCR and the video monitor.

Connect one end of the appropriate control cable to Play VCR A's control jack (3), and the other end to Edit Suite's VCR CONTROL A port. This VCR is now Play VCR A. Repeat this step for your other Play VCRs (6-8). Ensure that the port you select on Edit Suite matches the port to which the VCR/camcorder is attached on the mixer/switcher.

- **The output monitor's input switch**

It may be necessary to set the video monitor input switch. If the video monitor you are using has an input selection switch, set it so it displays the correct input. For instance, if you have connected to the monitor's VIDEO 1 input jack, you would choose VIDEO 1 as your input. Refer to the manual that came

with your monitor for details.

- **The Record VCR input**

It may also be necessary to set the Record VCR input switch. This step is important. Set the VCR's controls so that it will record whatever comes into its VIDEO IN jack, rather than recording a broadcast channel from the internal tuner. Different VCRs use different methods to do this. Your VCR's manual should explain how, probably in a section that discusses copying tapes from a camcorder. Here are some common examples:

- Most VCRs have an input selector switch that goes between LINE (or AUX, EXT, A/V, or S) and TUNER:

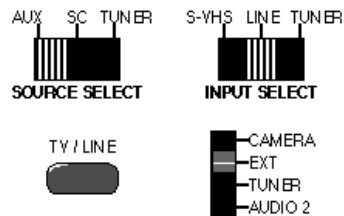

- Some use a button on the remote control or an on-screen menu to choose an external line source.
- Others require that you choose a special channel (like 99 or A1).
- Still others switch automatically when you plug the cable into the VIDEO IN jack.

- **The optional time code cables**

If your source videotapes contain prerecorded VITC or LTC and your Play VCRs accommodate it, take advantage of this capability. You will need to determine whether your VCR feeds time code over the edit control cable or externally via a separate audio/video (LTC/VITC respectively) output jack.

External connections require an RCA-style cable. Connect one end of a suitable cable to Edit Suite's TIME CODE IN port and the other end to the TIME CODE OUT, Video OUT (VITC), or Audio OUT (LTC) port on your VCR. If you only have a single output on your VCR, you can use a Y-splitter to split the audio/video signal at Edit Suite. Attach the splitter to Edit Suite.

- **The mixer and titler**

If you are using a video mixer or switcher, use a stereo GPI-cable to connect the mixer to Edit Suite's GPI-M (1) port. If you have a titler, use a GPI-cable to connect the titler to Edit Suite's GPI-T (2) port. Connect the audio and video signals from the play VCRs and camcorders to the mixer/switcher. Run the mixer's output through the titler, and run the titler's output to the record VCR.

- **Check the connections**

Turn on Edit Suite, all VCRs, video monitors and other equipment. Insert videotapes into your Play VCRs.

Press [A], then either press a transport-control key or rotate the jog/shuttle wheel. VCR A should begin to move and the time code display at Edit Suite should begin to update. Repeat this step for each VCR attached. If any problems are detected, refer to Step 9, *Troubleshooting*, in Chapter 3, *Getting Started*.

Appendix D • Edit Control Chart

	Sony LANC (CONTROL-L) Beta/EDBeta VHS/SVHS	Sony LANC (CONTROL-L) Video 8/Hi8	Matsushita Panasonic 5-Pin (CONTROL-M) VHS/SVHS	RS-232C Serial Interface	RS-422A Serial Interface (Uniquely Addressable)
RTC Real Time Counter (H:M:S)	Counter is a derivative of control track pulses. Accuracy is good. About ± 7 frames. Note: Control L does not send 10th of second interval externally.	Counter is a derivative of hub turn pulses. Accuracy is fair. About ± 15 frames. Note: Older Video 8 with RTC would continue to count when no video is present. * See note 1 below	Counter is a derivative of control track pulses. Accuracy is good. About ± 7 frames. Note: A little more accurate than Control L due to 10th of a second pulses being sent externally.	Counter is a derivative of control track pulses. Accuracy is good. About ± 7 frames.	Counter is a derivative of control track pulses. Accuracy is good. About ± 7 frames.
RCTC Rewritable Consumer Time Code		Rewritable Consumer Time Code is sent down the Control L interface. Requires a source that can read it. Accuracy is very good. About ± 4 frames. * See note 2 below			
VITC Vertical Interval Time Code (video signal)	Time code is written in with video. Requires a device that can read it via a video cable. Accuracy is excellent ± 2 frames. * See note 3 below	Time code is written in with video. Requires a device that can read it via a video cable. Accuracy is excellent ± 2 frames. * See note 3 below	Time code is written in with video. Requires a device that can read it via a video cable. Accuracy is excellent ± 2 frames. * See note 3 below	Time code is written in with video. Requires a device that can read it via a video cable. Accuracy is excellent ± 2 frames. * See note 3 below	Time code is written in with video. Requires a device that can read it via a video cable. Accuracy is excellent ± 2 frames. * See note 3 below
SMPTE Time Code a.k.a. LTC- Longitudinal Time Code (audio signal)	Time code is written in an audio track. Requires a device that can read it via an audio cable. Accuracy is excellent ± 2 frames. * See note 4 below	Time code is written in an audio track. Requires a device that can read it via an audio cable. Accuracy is excellent ± 2 frames. * See note 4 below	Time code is written in an audio track. Requires a device that can read it via an audio cable. Accuracy is excellent ± 2 frames. * See note 4 below	Time code is written in an audio track. Requires a device that can read it via an audio cable. Accuracy is excellent ± 2 frames. * See note 4 below	Time code is written in an audio track. Requires a device that can read it via an audio cable. Accuracy is excellent ± 2 frames. * See note 4 below
Non Linear Counter (Hub Count)	Not accurate or usable in an edit controller environment.	Not accurate or usable in an edit controller environment.	Not accurate or usable in an edit controller environment.	Not accurate or usable in an edit controller environment.	Not accurate or usable in an edit controller environment.

1. Video 8 and Hi8 formats do not have Control Track. Therefore the hub turns are converted to H:M:S. This conversion is not very accurate. Some counters will not count if no video is present due to a special circuit that looks at the video. If no video is present it will not allow the counter to increment.

2. RCTC is written at the trailing edge of video. It can be read when a source VCR is in pause (must be a four head). Can also be read during most shuttle movements. RCTC is also rewritable without affecting the video. RCTC is transmitted via Control L interface.

3. VITC is written in the vertical interval of video. It can be read when a source VCR is in pause (must be a four head). Can also be read during most shuttle movements. VITC cannot be read during FF or REW on most VCRs. During FF or REW Control Track information is substituted until the VCR is back into play mode.

4. LTC is written in an audio channel. It cannot be read when a source VCR is in pause. Can only be read during play and sometimes play X2. It also cannot be read in most shuttle movements or FFR/REW modes. During FF or REW control track information is substituted until VCR is back into play mode.

Appendix E ◦ Key Reference

Reference by Function:

Creating/Updating Events

To create ...	Press ...
Any Event	[NEW], move cursor to type, [OK]
Scene Event, empty	[SHIFT]+[A/B/C/D] for any source whose PROTO is not NONE.
Scene Event, with In or Out Time	Select source, press [SHIFT]+[IN/OUT]
Scene Event, with In or Out Time	If current source (steady LED) is different than the source for active EDL event – press [IN] or [OUT]. If current source is the same as the source for the active event, pressing [IN] or [OUT] updates time codes in the active event.
Scene Event with In Time and Start the Recorder (Assemble Edit)	[REC] (Then press [OUT] to pause recorder and fill in the OUT time.)
Source Event, ABCD	[SHIFT]+[A/B/C/D] for any source whose PROTO=NONE
Source Event, MX-1 Color	[SHIFT]+[COLOR]
GPI-T Event, Fixed with Time Code	[GPI-T] If the current source (steady LED) is different than source for the active EDL event, a scene event is created ahead of the GPI event.
MX1, MIXER or GPI-M Event (Depends on setting for GPI-M in Setup/Config)	[GPI-M] If the GPI-M port is configured for MX-1 or MIXER, and if active event is the last event in the EDL, the MX1/MIXER Event is followed by a new scene event. If the GPI-M port is configured for GPI, and if the current source (steady LED) is different than source for the active EDL event, a scene event is created ahead of the GPI event.
Insert Event	[INSERT], or press [R] then [IN] or [OUT].
Split Event	[SHIFT]+[SPLIT/INSERT] (but only if it follows an INSERT event).

Deleting

To do this ...	Press ...
Delete the Contents of an Event	[DELETE]+[NEW]
Cut an Event	[CUT]
Delete a Single Event	[DELETE]+[CUT]
Delete a Group of Events	[SHIFT]+[DELETE]+[CUT]
Delete all GPI-M/T Events in a Group	[DELETE]+[GPI-M/GPI-T]
Delete all GPI-M/T Events in the EDL	[SHIFT]+[DELETE]+[GPI-M/GPI-T]
Delete all Stop Events	[SHIFT]+[DELETE]+[ALL STOP]
Delete Entire EDL	[SETUP], EDL function
Delete all Configuration Information (Reset CONFIG to factory settings)	With an EDL event displayed, [SHIFT]+[DELETE]+[SETUP]
DELETE Everything (Reset entire unit to factory settings)	Unplug Edit Suite then press [SHIFT]+ [ALLSTOP] while reattaching power.

Displaying

To Display the ...	Press ...
New Menu	[NEW]
Setup Menu	[SETUP]
Configuration Menu	[SETUP], move to CONFIG, [OK]
EDL	If in NEW Menu, press NEW again. If in SETUP Menus, press [SETUP] to step back through the Setup Menus. If in live VCR screen, press [OK].
Time for Current Source (Live VCR)	[A/B/C/D]
Video from active event	[GO TO]+[IN/OUT]
Last Error Message Displayed	[SHIFT]+[OK]

Moving

To Move ...	Press ...
Up/Down/Left/Right	[Arrow Keys]
To Any Position in a Numeric Field	[CHG], then [SHIFT]+[left/right arrow]
To Top/Bottom of EDL	[GO TO]+[Up/Down Arrow]
To Previous/Next Scene or Source	[SHIFT]+[Up/Down Arrow]
To Previous/Next Stop	[GO TO]+[SHIFT]+[Up/Down Arrow]
To Specific EDL Event	[GO TO]+[OK], press [CHG], enter EDL number, then press [OK]
To In/Out Time on Video	[GO TO]+[IN/OUT]

MX-1 Related Functions

To ...	Press ...
Change MX1 Current Output	Press [A/B/C/D] or [COLOR]
Change MX1 Next Output	[GO TO]+ [A/B/C/D] or [COLOR]
Toggle MX1 Preview Display between next, current and preview.	[SHIFT]+[CHANGE]
Freeze Mixer Output (cannot be saved in EDL)	[SHIFT]+[GPI-M]

Rearrange/Renumber EDL Events



To ...	Press ...
Move an Event	[CUT], display new location, [PASTE]
Copy an Event	[COPY], display new location, [PASTE]
Move a Group of Events	[SHIFT]+[CUT], display new location, [PASTE]
Copy a Group of Events	[SHIFT]+[COPY], display new location, [PASTE]
Renumber Events	[GO TO]+[SHIFT]+[CHG]

Reference by Key:







Power Key

	[POWER] turns power to the unit on and off. When turned on, Edit Suite runs through a start-up routine then redisplay the event that was current when Edit Suite was turned off, or the Demo screens (if they have not been turned off via the SETUP/DEMO function).
---	--

VCR/Source Selector Keys







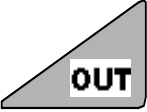

	<ol style="list-style-type: none"> [A, B, C, D] selects a current source. Also selects the output for the MX-1. The current source is controlled with the transport keys and the jog/shuttle. [SHIFT-A, B, C, D] creates a new scene or source event <i>after</i> the currently displayed event. (Scene if PROTO≠NONE; Source if PROTO=NONE.) [GO TO-A, B, C, D] when connected to an MX-1, sets the “Next” video source on the MX-1 and transfers VCR control to the selected Edit Suite port.
	<ol style="list-style-type: none"> [R] allows the Record VCR to be controlled.
	<ol style="list-style-type: none"> [COLOR] selects background color as the output for the MX-1. [SHIFT]+[COLOR] selects background color as the output for the MX-1 and creates a source event with the COL=0.





Production Keys

	<ol style="list-style-type: none"> [REC] starts an assemble edit, starts the recorder, and creates a scene event. [SHIFT]+[AUTO REC] starts an auto-assembly, commencing from the currently displayed EDL event.
	<ol style="list-style-type: none"> [PREVIEW] starts a preview of the EDL, commencing from the currently displayed EDL event. [SHIFT]+[REVIEW/PREVIEW] displays the last edit recorded on your Record VCR. (Cannot be used if the record VCR is controlled with IR.)
	<ol style="list-style-type: none"> [INSERT] creates an Insert edit. [SHIFT]+[SPLIT/INSERT] creates a Split Insert event. Must follow an Insert or nothing is created.
	<ol style="list-style-type: none"> [GPI-M] creates either an MX1, MIXER or GPI event depending on the GPI-M Configuration parameter. [DELETE]+[GPI-M] deletes all GPI-M events from the current group. [SHIFT]+[DELETE]+[GPI-M] deletes all GPI-M events from the EDL.
	<ol style="list-style-type: none"> [GPI-T] creates a GPI-T event. [DELETE]+[GPI-T] deletes all GPI-T events from the current group. [SHIFT]+[DELETE]+[GPI-T] deletes all GPI-T events from the EDL.
	<ol style="list-style-type: none"> [IN] updates the IN time code in the current event or creates a new event if the active source is different from the source in the current event. [SHIFT]+[IN] creates a new event for the current source and enters the IN time. [GO TO]+[IN] repositions the source VCR to the IN time for the current event.

	<ol style="list-style-type: none"> 1. [OUT] updates the OUT time code in the current event or creates a new event if the active source is different from the source in the current event. 2. [SHIFT]+[OUT] creates a new event for the current source and enters the OUT time. 3. [GO TO]+[OUT] repositions the source VCR to the OUT time for the current event.
---	--







Function/Numeric Keypad

	<ol style="list-style-type: none"> 1. [UP ARROW] moves the cursor up through the EDL. 2. [SHIFT]+[UP ARROW] moves to previous Scene or Source event. 3. [GO TO]+[UP ARROW] moves to the first event in the EDL. 4. [SHIFT]+[GO TO]+[UP ARROW] moves to previous Stop event.
	<ol style="list-style-type: none"> 1. [DOWN ARROW] moves the cursor down through the EDL. 2. [SHIFT]+[DOWN ARROW] moves to the next Scene or Source event. 3. [GO TO]+[DOWN ARROW] moves to the last event in the EDL. 4. [SHIFT]+[GO TO]+[DOWN ARROW] moves to the next Stop event.
	<ol style="list-style-type: none"> 1. [LEFT ARROW] moves the cursor left from field to field in an event. 2. [SHIFT]+[LEFT ARROW] in CHG mode moves the cursor within a numeric field.
	<ol style="list-style-type: none"> 1. [RIGHT ARROW] moves the cursor right from field to field in an event. 2. [SHIFT]+[RIGHT ARROW] in CHG mode moves the cursor within a numeric field.
	<ol style="list-style-type: none"> 1. [NEW] displays the NEW Menu. 2. [SHIFT]+[NEW] inserts the next event created with the New menu <i>before</i> the current EDL event. 3. [DELETE]+[NEW] clears all field values of the current EDL event.
	<ol style="list-style-type: none"> 1. [CUT] cuts the currently displayed event from the EDL and stores it in temporary buffer memory, erasing the buffer's previous contents. 2. [SHIFT]+[CUT] cuts the currently displayed group from the EDL and stores it in temporary buffer memory, erasing the buffer's previous contents. 3. [DELETE]+[CUT] deletes the currently displayed event from the EDL but preserves the contents of temporary buffer memory. 4. [SHIFT]+[DELETE-CUT] deletes the currently displayed group from the EDL but preserves the contents of temporary buffer memory.
	<ol style="list-style-type: none"> 1. [COPY] creates a copy of the currently displayed EDL event and stores it in temporary buffer memory, erasing the buffer's previous contents. 2. [SHIFT]+[COPY] creates a copy of the currently displayed group and stores it in temporary buffer memory, erasing the buffer's previous contents.
	<ol style="list-style-type: none"> 1. [PASTE] pastes the contents of the temporary buffer after the currently displayed event. 2. [SHIFT]+[PASTE] pastes the contents of the temporary buffer ahead of the currently displayed event.

	<ol style="list-style-type: none"> 1. [DUR] displays and allows changes to be made to the duration of the current event. □
	<ol style="list-style-type: none"> 1. From the EDL, [SETUP] displays the first of two Setup Menus. Pressing [SETUP] while either of the two menus is displayed takes you back to the last-displayed EDL event. 2. [SHIFT]+[DELETE]+[SETUP] from the EDL resets the Configuration parameters to factory default settings. 3. [GO TO]+[0/Setup] rewinds VCRs and camcorders whose PROTO is LANC or PANA, and resets their counters to 0000.
	<ol style="list-style-type: none"> 1. [CHG] cycles through choices in a choice list or activates the numeric keys when in a numeric field. 2. [SHIFT]+[CHG] when connected to an MX-1, cycles the MX-1 display between the Next Source, the Current Source and the Preview Screen. 3. [SHIFT]+[GO TO]+[CHG] resequences all EDL event numbers. □
	<ol style="list-style-type: none"> 1. [OK] accepts changes made to a field value. 2. [SHIFT]+[OK] redisplay the last error message. 3. [GO TO]+[OK] accesses the Go To Event# function. (Finds the event whose number is entered.)

Transport Keys

Note: Except as indicated below, the transport keys cannot be used to control a record VCR that uses IR control.

	<ol style="list-style-type: none"> 1. Pressing [Rew] during VCR play, places the VCR into reverse fast scan mode. Pressing [Rew] after [Stop] unloads the videotape from the heads and places the VCR into a high-speed rewind. 2. When selecting an IR (infrared) table for the Record VCR, pressing REW selects the next lower table number, builds the table, and sends a Record Pause command for that table out the IR Wand.
	<ol style="list-style-type: none"> 1. [Stop] halts all VCR movement. 2. [SHIFT]+[Stop] applies to RS-232 and RS-422 VCRs only and is used to reset the communication link between Edit Suite and the selected VCR. This is used most often with Sony RS-232 VCRs like the SVO-9720.
	<ol style="list-style-type: none"> 1. [Pause] places the VCR into pause mode. 2. Used in the Configuration Menu to test the record VCR for IR control.
	<ol style="list-style-type: none"> 1. [Play] places the VCR into Play mode. 2. [Play] causes Edit Suite to update the time code display in a live VCR screen.
	<ol style="list-style-type: none"> 1. Pressing [Fast Forward] during VCR play, places the VCR into forward fast scan mode. Pressing [Fast Forward] after [Stop] unloads the videotape from the heads and places the VCR into a high-speed fast forward. 2. When selecting an IR (infrared) table for the Record VCR, pressing REW selects the next higher table number, builds the table, and sends a Record Pause command for that table out the IR Wand.
	<ol style="list-style-type: none"> 1. [ALL STOP] halts all VCR motion and EDL activity—such as an auto-record. 2. [SHIFT]+[DELETE]+[ALL STOP] deletes all STOP Events from the EDL. 3. [SHIFT]+[ALL STOP] while plugging in the Edit Suite power cord deletes all EDL and Configuration information and resets Edit Suite to factory conditions. The message NVRAM INIT displays when power is connected.

Index

- A/A Roll 23
- A/B Roll 25, 36, 43, 48
- A/B/C/D/R Keys 8
- A/X/A Roll 43
- Accuracy 38, 73
- Adjusting the Offset Parameters 73
- Advanced Parameters 17, 92
- All Stop 11
- Assemble Editing 29
- Asterisks (***) in display 105
- Auto-Assemble Editing 30
- Auto-Record 24, 31
- Beeper 88
- Beeper doesn't beep. 105
- Cables 2, 13, 21
- Cables and Cable Pinouts 117
- Changing the Event Number 39
- CMX 83, 88
- COLOR Key 8
- Communication Programs and Settings 79
- Configuration Menu 14, 88, 89
- Copying Events 67
- Creating/Updating Events 127
- Cut From Scene to Scene 36, 48
- Definition Parameters 90
- Deleting Events 70, 128
- Deleting the EDL 71, 128
- Demo 88
- Display Previous/Next Scene or Source 64
- Display Previous/Next Stop 65
- Display Specific Event 65
- Displaying Menus and Events 128
- Edit Control Chart 125
- Edit Decision List (EDL) 4, 63, 88
- EDL corrupt 101
- EDL empty 101
- EDL full 101
- Equipment Hookup 14, 121
- Error Messages 99
- Event Numbers Out of Sequence 106
- Events
 - GPI 51
 - Insert 55
 - Mixer 48
 - MX1 43
 - Scene 36
 - Source 40
 - Split Insert 59
 - Stop 61
- Export 81, 88
- Fade Up From Black 40
- Fine Tuning 73
- Frames not incrementing 106
- Function/Numeric Keypad 8, 131
- Getting Started 13
- GPI Events 51
- GPI not Triggered 106
- GPI-M Key 46, 49, 53
- GPI-M Port 20
- GPI-M/T Configuration 97
- GPI-T Key 53
- Hookup 14
- Import 88
- Importing and Exporting 79
- IN Offset 75
- Inaccurate Scene 106
- Infrared Code List 115
- Infrared – Configure and Test 18
- INS 92
- INS Event Created 107
- Insert (INS) Events 55
- Insert not available 103
- InsIN/OUT Offset 57
- Invalid ED Number 103
- Invalid primary tile 102
- Jog Failure 106
- Jog/Shuttle 10
- Key Reference 127
- LANC (Control-L) Protocol 110
- LCD 7, 87
- LCD Hard to Read 107
- LEDs 8
- Making a Production 29
- Managing The Edit Decision List 63
- Match Frame Edits 44
- Missing Scene 107
- Mixer Events 48
- Mixer/Switcher 36
- Modifier Keys 12
- Move to Top/Bottom of EDL 63
- Moving Events 66, 129
- MSGs 88
- MX-1 Color 42
- MX-1 Color Not Updated 107
- MX-1 Related Functions 129
- MX1 Events 43
- New Menu 34
- NEWVCR 88
- No LTC found 102
- No MX-1 found 103

No response from VCR 100
No valid group found 101
No VITC found 102
Numeric Entry 37
NVRAM INIT 82
Off-Line Logsheet 135
Offsets 74
OUT Offset 74
Out pt before in pt 38, 99
Overview of Edit Suite 2
Overview of the Keyboard 7
PANA (Panasonic Control-M) Protocol 109
Play VCRs IN OFFSET 76
Play VCRs OUT OFFSET 74
Power Key 129
Power Supply 14
Precautions 31
Preroll 91
Preview 24
Production Hints/Precautions 31
Production Keys 9, 130
PROTO 91
PROTO (protocol) 15
Rearrange/Renumber EDL Events 129
REC 30
Record 24
Record VCR (VCRR) IN and OUT OFFSETS 75
Renumbering the EDL 72
Review Last Scene 31
RS-232 Protocol 113
RS-422 Protocol 112
Scene (A/B/C/D) Events 36
Scene Event 23
Search Parameters 92
Setup and Configuration Menus 87
Setup Menu 14
Simultaneous Rolling of Two VCRs 45
Slow Response 105
Source (SRC) Events 40
Split delay out of range 100
Split Insert (SPLT) Events 59
Split not available 103
SPLT 92
SPLT Offset 59
SRC Event is Short 108
Stop Events 61
Switching Sources with a Third-Party Mixer 48
Tape address not found 100
TC (time code type) 17, 91
TCSRC (time code source) 17, 91
Testing and Troubleshooting VCR Connections 21
Third-Party Mixer/Switcher 48
Time Code 3, 91, 109, 125
Transport Keys 10, 133
Troubleshooting 105
Tuning Parameters 92
VCR (VCR Table Number) 16, 91
VCR Cannot be Controlled 108
VCR Definition Parameters 90
VCR not specified 103
VCR number not available 100
VCR Search (Advanced) Parameters 92
VCR table corrupt 101
VCR table too large 101
VCR Tables 109
VCR Tuning Parameters 92
VCR/Source Selector Keys 8, 130

Edit Suite

Version 2.01 Addendum

Edit Suite Version 2.01 adds support for the Videonics MXPro Mixer, provides new VCR Control Tables and enhances the GPI trigger signal.

If you are already familiar with Edit Suite, the information in this addendum should be all you need to begin using Version 2.01. If you are new to Edit Suite, glance over the information in the addendum to see which areas of the product have changed, then use the Edit Suite Instruction Manual to learn how to use the product. Supplement the information in the manual with the information in this addendum.

Change Summary on this page is a brief listing of the changes for Version 2.01. *Change Details*, on the following pages, provide more detailed information about each of the changes.

Change Summary

A. Changes to Support MXPro

1. How to Select Press Setup, select Config, then select GPI-M. Choices are GPI-M = MXPRO (default), MX-1 and MIXER. GPI-M = GPI choice removed. "MX1" choice in the NEW tile changed to "MX."
2. NEW tile
3. MX tile
 - Effect (FX) Number FX=000-706 (was FX=000-239)
 - Tile Type label shows as MX1 or MXP, depending on GPI-M choice
 - Speed SP=_ (same as previous Edit Suite versions)
 - Background Color C=_ (was BG=_)
 - Border Color B=_ (was BC=_)
 - Style (Border Style) S=_ (added to all MX tiles but only sent if GPI-M = MXPro)
4. Error Message 21 Changed wording: No MX1/MXPRO found.

B. New/Replaced VCR Control Tables

1. Pana_046 and 047 For Panasonic PV-4680, 4690 and 7680
2. Pana_100 (and Lanc_100) For Panasonic NV-DE3 digital camcorder; for devices that require a long pause after a Stop command.
3. Lanc_101 (and Pana_101) If Lanc (or Pana) randomly remains in Play-Pause or Record-Pause during auto-assemble (auto record).
4. RS232_111, 113, 114 , 115 For RS232 VCRs if RS232_001, 003, 004 or 005, respectively, had problems when used as a play VCR
5. RS422_009 For RS422, enhances insert editing with 422 VCRs
6. RS422_111, 119 For RS422: May help if auto assemble pauses abnormally.
7. IR Tables Several IR tables have been replaced.

C. Change to GPI trigger signal



Some third-party devices, such as JVC titlers, would not trigger (play) with previous versions of Edit Suite. The GPI pulse was modified to support these devices.

Change Details

A. Changes to Support MXPro

1. How to Select

To select the type of mixer (if any) that will be attached to the GPI-M port:

- a. Press  to display Setup Menu 1, then press  to move the cursor to CONFIG.



```
LCD_CONFIG NEWVCR
IMPORT EXPORT CMX ▾
```

Setup Menu 1

- b. Press  to display the Configuration Menu (cursor will be under VCRA choice).

```
VCRA VCRB VCRC VCRD
VCCR GPI-M GPI-T
```

Configuration Menu

- c. Press  and  to move the cursor to the GPI-M choice, then press  to display the GPI-M Configuration Parameters screen.

```
VCRA VCRB VCRC VCRD
VCCR GPI-M GPI-T
```

Configuration Menu (GPI-M selected)

```
GPI-M =_MXPRO
```

Configuration Parameters

- d. Press  multiple times to cycle through the three choices: MXPRO (default), MX-1 and MIXER. Select MXPRO if you will be using a Videonics MXPro mixer; select MX-1 for the Videonics MX-1, or select MIXER for a third-party mixer/switcher. The MIXER choice has an associated offset value. Leave the offset value set to +0000 initially.

NOTE: In previous versions of Edit Suite, there was also a choice for GPI-M = GPI. This choice has been removed from Version 2.01. Use the GPI-T port to connect non-mixer GPI devices.

- e. Press  twice to exit the Setup menus.

2. NEW Tile

To display the NEW tile, press . The only change to the NEW tile is that the MX1 choice has been changed to "MX." Use MX to create tiles for either the MX1 or the MXPro: the same tile is used for both.

```
MX A B C D SRC GPI
MIXER SPLT INS STOP
```

Version 2.01 NEW Menu

```
MX1 A B C D SRC GPI
MIXER SPLT INS STOP
```

Previous NEW Menu

3. MX Tile

Several changes have been made to the MX tile:

```
002/003 FX=539 DI=>
MXP SP=5 C=5 B=3 S=1
```

Version 2.01 MX Tile

```
002/003 FX=001 DI=>
MX1 SP=5 BG=0 BC=
```

Previous MX Tile

- Effect (FX) numbers can be up to 706.
- The tile type (MXP or MX1) indicates your choice for GPI-M. (If GPI-M=MXPRO, MX tile type = MXP; otherwise, tile type = MX1.)
- Speed is indicated by SP=_ (same as previous versions).
- Background Color is indicated by C=_ (was BG).
- Border Color is indicated by B=_ (was BC).
- Style (border style) is indicated by S=_. (New for MXPro; not sent to MX1)

About Effect Numbers:

- Valid effect numbers for an MX-1 are 000-239. For an MXPro, they are
 - 000-239 (MX1 "basic" effects)
 - 300-353 (Edge transitions)
 - 400-429 (Trailing effects)
 - 500-706 (Shape effects).
- If a number greater than 706 is entered, it is changed to 706.
- If a number between the number groups is entered, it is changed to the next lower valid number. For example, if effect number 295 is entered, it is changed to 239.
- If GPI-M is set to MX1 and an effect number greater than 239 is specified, effect number 001 (dissolve) is sent to the MX1 during an edit operation.

About Style Numbers:

- The Style field is included in all MXP and MX1 tiles, but style only applies to the MXPro. For MX1 users, you can ignore the field: the style information is not sent to the MX1. For MXPro users, refer to the MXPro documentation for more detailed information.)
- Style (border style) values are between 0 (zero) and 9. Zero means that borders will not be used with the selected transition. Values 1-9 specify a border width for effects 000-239, and a border style for effects 300-706. (Borders do not apply to trailing effects.)

4. Error Message 21

Error message 21 now applies to either the MX-1 or the MXPro, whichever is selected in Setup->Config->GPI-M.

```
ERROR No MX-1/MXPRO
21 found
```

The message displays if an operation that requires an MXPro or MX-1 (such as pressing the GPI-M button) was done, but Edit Suite was not able to communicate with the MXPro/MX-1. This would occur if a GPI cable is not connected between Edit Suite's GPI-M port and the MXPro/MX-1 or if the MXPro/MX-1 is not turned on.

B. New/Replaced VCR Control Tables

Several VCR Control Tables have been added to Version 2.01, and several IR tables have been replaced:

1. Pana_046 and 047

These tables add support for Panasonic PV-4680, 4690 and 7680 VCRs.

The Edit Suite jog/shuttle control for these VCRs is limited and may provide inconsistent results. Instead of using the Edit Suite jog/shuttle, we suggest you use the Edit Suite transport keys (Play, Pause, Cue) for rough positioning and the VCR's shuttle knob for fine positioning.

Also note, these tables do not support insert editing when the PV-4680, 4690 or 7680 is used as the record VCR.

Table 046 was available previously, but only via the NEWVCR function, and if Edit Suite reset (NVRAM INIT), the table needed to be reentered. In this version, table 046 is permanently in the software so it never needs to be entered/reentered via the NEWVCR function. Just select it like you select any other VCR table.

Table 047 is new for version 2.01 and may provide slightly better results when the above VCRs are used as source VCRs (rather than as recorders). The only difference between table 046 and 047 is the amount of time Edit Suite waits after sending some commands before it sends the next commands. In some tests, there was not enough wait time in table 046, so the VCR sometimes went into pause mode when it should have been in play mode. Table 047 fixed these problems.

2. Pana_100

For Panasonic NV-DE3 digital camcorder and other camcorders/VCRs that have the symptom described below.

With other Edit Suite tables, the camcorder worked fine for most operations (play, cue, review, go-to, etc.), but failed to do an auto-record. The camcorder would stop or pause prior to the first edit point and fail to recover. The problem dealt with the amount of time the camcorder needed to wait after certain commands were sent; table 100 fixes this problem.

Lanc_100

This table has the same change as the Pana_100 table. There are no Lanc VCRs/camcorders we know of that require this table. However, should you encounter a Lanc device that exhibits the same problem as described in the Pana_100 table, try using this table to fix the problem.

3. Lanc_101

If Lanc is used as the source VCR/camcorder and the source randomly remains in Pause during an auto-assemble, or if a Lanc device is used as the record VCR and the record VCR randomly remains in Record-Pause, use this table to fix the problem.

A problem was found with some combinations of Lanc and RS422 devices that caused the Lanc device to remain in pause or record pause at the start of some scenes.

More specifically, if Lanc was used as the source and RS422 as the recorder, the source would randomly pause at the preroll point for an edit and remain there forever. If the reverse setup was used (RS422 as player/Lanc as recorder), the Lanc VCR would be in record-pause at the end of a scene but never leave record pause to record the following scene.

Pana_101

This table has the same changes that were made for Lanc_101. We know of no combination of VCRs that require this table. However, if you have symptoms similar to those described for table Lanc_101, try using this table to fix the problem.

4. RS232_111, 113, 114 , 115

These tables are for RS-232 VCRs when used as source (rather than record) VCRs; they should be used only if there are problems with the corresponding "base" tables during auto-record.

USE:	IF THIS TABLE FAILS:
RS232_111	001 (most Sony RS232 VCRs)
RS232_113	003 (most Panasonic RS232 VCRs)
RS232_114	004 (most JVC RS232)
RS232_115	005 (Sony UVW-1400 RS232)

The problem these fix is that, during auto-assemble, the RS232 play VCR searched to the first preroll point, then paused forever. Tables 111, 113, 114 and 115 fix this problem by eliminating a time code check during auto-record.

5. RS422_009

This table enhances insert editing with RS422 VCRs. It was available previously via the NEWVCR function, but is now a permanent part of the software.

6. RS422_111, 119

These tables are similar to RS232 tables 111-115. There are no VCRs we know of that require this fix. However, if you encounter a problem similar to the one described the RS232_111 ... 115, try using these tables to fix the problem. Use table 422_111 instead of 422_001, or use 422_119 instead of 422_009.

7. IR Tables

To make room for the above tables, several IR tables have been replaced in this release. (Both the old tables and the replacement tables were available previously.) If you previously used one of the "old" tables, switch to the "new" table for this release.

Old Table	New Table	Old Table	New Table
003	105	036	115
013	110	037	116
014	104	039	117
015	106	040	118
016	109	041	119
017	107	046	120
019	111	047	121
021	103	050	122
022	112	056	123
024	113	058	127
026	101	059	124
029	102	060	125
035	114	061	126
		064	128

C. Change to GPI Trigger Signal

To add support for some GPI devices (such as JVC titlers) that were not supported in previous versions of Edit Suite, we changed the GPI trigger signal. The width of the trigger pulse was shortened (from 100ms to 50ms) and the GPI now initializes high and pulses low. All devices that worked previously will work with the new settings and devices that failed to trigger previously should now trigger satisfactorily.